

Low cost, high efficiency, wide input voltage range and low output noise define DATEL's new UNS Series of non-isolated, step-down, switching DC/DC converters.

FEATURES

- Low cost
- SIP or DIP packaging
- 3.3V (10W) or 5V (15W) outputs
- Wide range inputs:
4.75-13.6V for 3.3V models
6-16.5V for 5V models
- High efficiencies, typically 90-92%
- Low output noise, 50mVp-p
- Remote on/off control
- 100µA "standby" input current
- Output current limiting
- EMC compliant
- Highly reliable, 100% SMT construction
- Conformally coated for harsh environments

PRODUCT OVERVIEW

The 3.3V- and 5V-output devices are, respectively, 90% and 92% efficient. All models are fully line and load regulated and maintain specified accuracy over the impressively wide input voltage ranges of 4.75 to 13.6 Volts for 3.3V outputs and 6 to 16.5 Volts for 5V outputs. Output ripple and noise are typically 50mVp-p.

UNS devices are fabricated using proven SMT-on-pcb construction techniques. The 3.3V and 5V devices are both available in either lightweight SIP (2" x 0.4" x 0.8") or DIP (2" x 0.8" x 0.4", 600 mil spacing between rows) package configurations. The DIP option is designated by a "D" suffix added to the part number. All models are conformally

coated for protection against moisture and dust.

The high efficiency of the UNS Series' fixed-frequency (190kHz) switching design eliminates the need for thermally conductive potting compound. Devices are specified for full-power operation up to ambient temperatures of +50°C. With derating, they operate up to +70°C. Calculated MTBF (MIL-HDBK-217F) is more than 1.6 million hours.

These simple-to-use power converters have no minimum load requirements. They draw 1mA when unloaded and a mere 100µA in the standby mode (On/Off Control turned off). 3.3V models have an output voltage adjustment range of 2.7 to 3.3 Volts. 5V models are adjustable down to 3.0V.

SIMPLIFIED SCHEMATIC

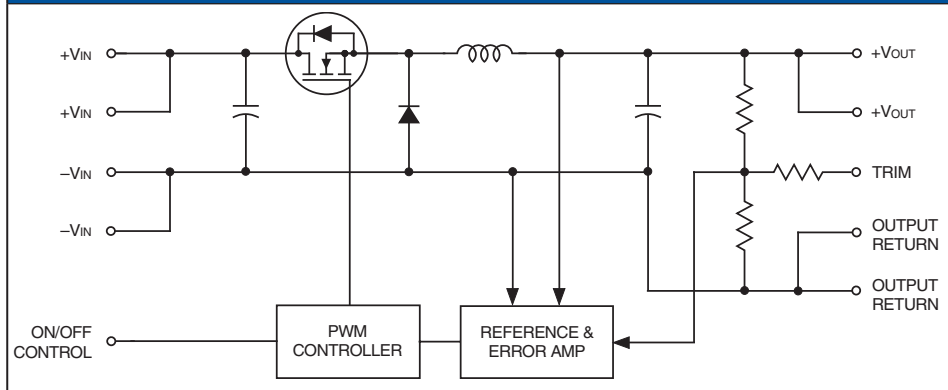

PERFORMANCE SPECIFICATIONS AND ORDERING GUIDE ^①												
Model Family ^②	Output						Input			Efficiency		Package (Case/ Pinout)
	V _{OUT} (V)	I _{OUT} (A)	R/N (mVp-p) ^③		Regulation (Max.) ^④		V _{IN} Nom. (V)	Range (V)	I _{IN} ^⑤ (mA)	Min.	Typ.	
			Typ.	Max.	Line	Load						
UNS-3.3/3-D5	3.3	3	50	100	±1.0	±3.0	7.5	4.75-13.6	1/1400	--	90%	B1, P18
UNS-3.3/3-D5D	3.3	3	50	100	±1.0	±3.0	7.5	4.75-13.6	1/1400	--	90%	B2, P18
UNS-5/3-D12	5	3	50	100	±1.0	±3.0	12	6-16.5	1/1330	--	92%	B1, P18
UNS-5/3-D12D	5	3	50	100	±1.0	±3.0	12	6-16.5	1/1330	--	92%	B2, P18

- ① Typical at T_A = +25°C under nominal line voltage and full-load conditions, unless otherwise noted.
- ② "D" suffix indicates DIP package.
- ③ Ripple/Noise (R/N) measured over a 20MHz bandwidth with a 100µF external input capacitor and a 220µF external output capacitor. Additional output capacitors will lower R/N. See Technical Notes.

- ④ Listed output regulation specifications describe the total change in output voltage as the input (line) voltage or output (load) current is varied over its full specified range. Typically, line regulation is better than ±0.5% and load regulation is better than ±1.0%. Load regulation applies for 0 to 100% load conditions.
- ⑤ Nominal line voltage, no-load/full-load conditions.

PART NUMBER STRUCTURE

UNS-3.3/3-D5D

Output Configuration:
U = Unipolar

Non-Isolated SIP packaging

Nominal Output Voltage:
3.3 or 5 Volts

Input Voltage Range:
D5 = 4.75-13.6 Volts (7.5V nominal)
D12 = 6-16.5 Volts (12V nominal)

Maximum Output Current in Amps

Add "D" suffix for optional DIP package configuration

Important: Do not include the "A" suffix when ordering.

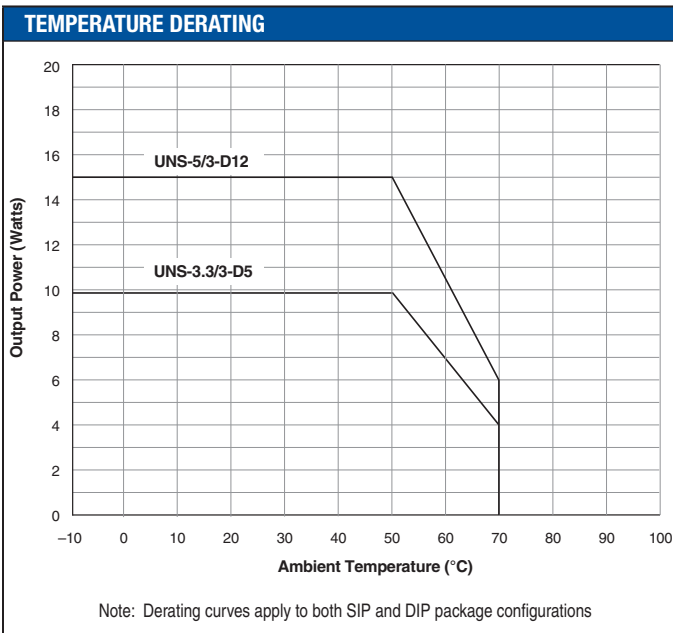

MECHANICAL SPECIFICATIONS

Case B1 (SIP)

Case B2 (DIP)

* NO CONNECTION. FOR MECHANICAL STABILITY ONLY.

DIMENSIONS ARE IN INCHES (MM)

INPUT/OUTPUT CONNECTIONS			
Pin	Function P18	Pin	Function P18
1	+Input	6	Trim
2	+Input	7	Output Rtn.
3	-Input	8	Output Rtn.
4	-Input	9	+Output
5	On/Off Control	10	+Output

Typical @ T_A = +25°C under nominal line voltage and full-load conditions, unless noted. ①

Input	
Input Voltage Range: "D5" and "D5D" Models "D12" and "D12D" Models	4.75-13.6 Volts (7.5V nominal) 6-16.5 Volts (12V nominal)
Input Current	See Ordering Guide
Input Filter Type	Capacitive
Overvoltage Protection	None
Reverse-Polarity Protection	None
On/Off Control (Pin 5) ②	TTL high (or open) = on, low = off
Output	
V_{out} Accuracy	±5%, maximum
Temperature Coefficient	±0.01% per °C
Ripple/Noise (20MHz bandwidth) ③	See Ordering Guide
Line/Load Regulation ④	See Ordering Guide
Efficiency	See Ordering Guide
Current Limiting ⑤	Auto-recovery
Dynamic Characteristics	
Transient Response (50% load step)	200µsec max. to ±2% of final value
Switching Frequency	190kHz
Environmental	
Operating Temperature: Without Derating With Derating	-10 to +50°C to +70°C (See Derating Curve)
Storage Temperature	-25 to +85°C
Physical	
Dimensions: SIP Models DIP Models ⑥	2 x 0.41 x 0.8" (50 x 10.3 x 21mm) 2 x 0.8 x 0.44" (50 x 21 x 11.3mm)
Shielding	None
Case Connection	None
Pin Material	Gold-plated phosphor bronze
Weight	0.35 ounces (10 grams)

- ① UNS Series devices require external input/output capacitors to achieve rated performance. Listed specifications assume C_{IN} = 100µF and C_{OUT} = 220µF.
- ② See Technical Notes.
- ③ Output Ripple/Noise can be reduced with external capacitors. See Technical Notes.
- ④ UNS Series converters have no minimum-load requirements.
- ⑤ Current limiting initiates at approximately 5% above rated load.
- ⑥ DIP models have a standoff which makes their total above-board height 0.44 inches.

Absolute Maximum Ratings	
Input Voltage: "D5" Models "D12" Models	15 Volts 18 Volts
Input Reverse-Polarity Protection	None. See Technical Notes.
Output Overvoltage Protection	None
Output Current	Current limited. Devices can withstand an output short circuit for brief durations only.
Storage Temperature	-25 to +85°C
Lead Temperature (soldering, 10 sec.)	+300°C

These are stress ratings. Exposure of devices to any of these conditions may adversely affect long-term reliability. Proper operation under conditions other than those listed in the Performance/Functional Specifications Table is not implied.

TECHNICAL NOTES

Input and Output Capacitors

Though UNS Series, non-isolated, DC/DC converters have on-board input and output capacitors (C_{IN} = 6.8µF, C_{OUT} = 6.8µF), the majority of applications will require the installation of additional external I/O capacitance.

The total input capacitance functions as a true energy-storage element, and its optimal value will vary as a function of line voltage. The selected external input capacitor should have both low ESR and low ESL because, as the power converter's input FET switch cycles on and off, the input capacitance must have the ability to instantaneously supply pulses of relatively high current.

Rather than install a large, expensive, on-board capacitor that addresses all possible input-voltage and output-load conditions, DATEL has chosen to leave out the bulk of the input capacitance so that users may select a cost-effective component appropriate to their own application. We use a low-ESR 100µF external input capacitor during production testing.

Foldback Autorecovery – models with the "A" suffix only

For "A" suffix models only, as output current exceeds the rated limit, current will be sharply reduced using the foldback current limit technique. As current is further reduced to a low value, the converter will automatically recover normal operation and rated output voltage.

The exact current where autorecovery occurs is dependent on the reactance of the output load and whether the output load has any "constant current" characteristics at start up. On "A" suffix models, some types of heavy "constant current" loads may fail to start up properly. This can be offset by adding required external capacitance (see below). Normal resistive loads will autorecover near the rated full current limit.

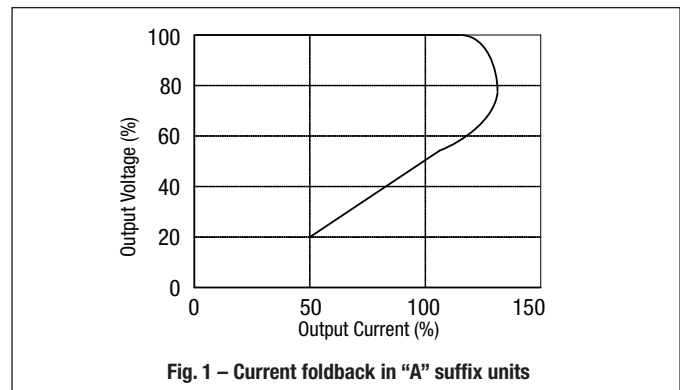

Output Capacitance is Required

Almost all applications must add external output capacitance to improve stability, start-up characteristics and to reduce noise. DATEL recommends approximately 330µF as a starting point using low-ESR capacitors such as the Sanyo OSCON or Poscap series. Use a capacitor voltage rating twice the expected output voltage. Lower capacitance and/or higher ESR can cause instability with inductive loads. Higher capacitance can lead to poor transient response and sluggish regulation. Mount the capacitor close to the converter and keep leads short. You may need to experiment.

UNS 5 and 3.3 Volt Series Specification Revision Notice

Notice: As of January 2006, all models now include an "A" suffix marked on the unit to indicate a mandatory change in the PWM. Older models without the "A" suffix are now obsolete.

In late 2003, all UNS series 5 Volt output DC/DC converters improved some specifications and changed the trim values. These same changes were applied to 3.3 Volt output converters in January 2006. The new converters are designated with a trailing letter "A" in the model number (Example: UNS-5/3-D12DA) marked on the unit. *This designation is not used in the ordering model number – it only appears on the device itself.* These changes were unavoidable because of obsolescence of the PWM controller. Older models without the "A" suffix are no longer available.

All specifications are unchanged except the following:

Specification	"A" Suffix Models - revised specification
Line regulation	±0.2% typ., ±1.0% Max.
Load regulation	±0.2% typ., ±1.5% Max.
Input/output pins	0.64mm dia., Tin plated
Internal reference voltage, Vref	0.8 Volts
Overcurrent protection	Foldback current limiting

Output Trimming

5V devices can be trimmed down to 3.0V, and 3.3V devices can be trimmed down to 2.7V using a single external trimpot or fixed resistor. The trimpot should be connected between +V_{OUT} (pins 9 and 10) and Trim (pin 6) as shown in the figure below. The trimpot can be used to determine the value of a single fixed resistor which can then be connected between pins 9 and 10 and 6. Fixed resistors should be metal-film types with relatively low absolute TCR's to ensure stability.

In order to maximize their efficiency, UNS devices employ high-value resistors in their voltage feedback loop. Consequently, the external trimpots must also be high-resistance devices (1-2 megohms). If the trimpots are accidentally turned to their 0Ω stops, it will not damage the converters; however, the output voltage will be pulled down to an unstable level. Use care not to trim the output voltage below the levels indicated in the accompanying table.

RoHS-Compliance

RoHS (Reduction of Hazardous Substances) compliance is indicated *solely* by the manufacturing date code. All UNS-5V converters with date code "WM" (December 2005) or later are RoHS-compliant. All UNS-3.3V converters with date code "VF" (June 2006) or later are RoHS-compliant. Non-RoHS converters are no longer available. All RoHS models also include the "A" suffix changes.

Please note carefully that RoHS units do not include a "-C" suffix.

Date Codes

The manufacturing date code is a 2-letter code as follows:

First letter (year):

Y:2003, X:2004, W:2005, V:2006, U:2007, T:2008, S:2009, R:2010, Q:2011, P:2012, O:2013, N:2014, M:2015

Second letter (month):

A:January, B:February, C:March, D:April, E:May, F:June, G:July, H:August, I: not used, J:September, K:October, L:November, M:December

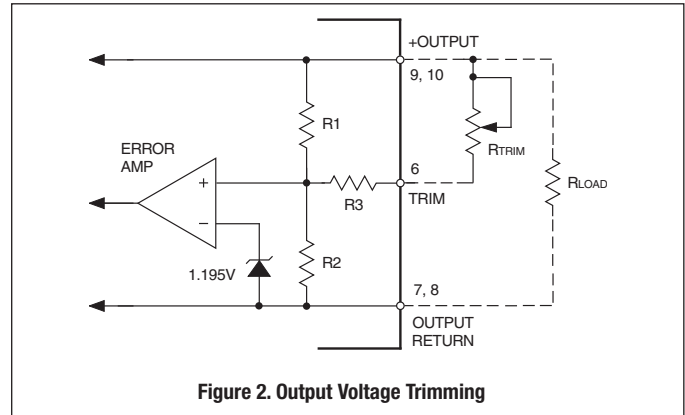

Figure 2. Output Voltage Trimming

5V and 3V Model Trim Values

Note that if you have not installed trim resistors to existing circuits, there is no change. Also, if you have installed a trim pot (instead of a fixed external trim resistor), you may only need to recalibrate the trim pot. The trim pot value normally does not need to change. If you do not install trim resistors, leave Trim pin 6 unconnected (open).

On the trim circuit diagram, Figure 2, use the following revised table:

Model Number	UNS-3.3/3 older models	UNS-3.3/3 "A" models	UNS-5/3 older models	UNS-5/3 "A" models
Output Voltage Adjustment Range	2.7 to 3.3V	2.7 to 3.3V	3.0 to 5.0V	3.0 to 5.0V
R1 Value	68.68KΩ	62.51KΩ	124.7KΩ	106KΩ
R2 Value	39KΩ	20KΩ	39KΩ	20KΩ
R3 Value	10KΩ	0Ω (short)	10KΩ	0KΩ (short)
Voltage Reference, Vref	1.195V	0.8V	1.195V	0.8V

"A" Model Trim Equation

$$R_{trim} = (R1 \times R2 (V_{out} - V_{ref})) / (R1 \times V_{ref} - R2 (V_{out} - V_{ref})) - R3$$

(R3 = 0Ω for "A" models)

Finally, please note that the trailing "A" suffix in the model number is *not* used for ordering these converters. Use the standard model numbers without the "A" suffix.

The On/Off Control Pin

For normal operation, pin 5 should be left open. This pin has an internal 250kΩ pull-up resistor to +5V (or to +V_{IN} if +V_{IN} < 5V). For dynamic control of the converters' on/off functionality, a TTL logic high (+2.4V minimum, +5V maximum or +V_{IN} maximum if +V_{IN} < 5V, 100μA max.) applied to pin 5 enables the converter, and a quasi-TTL logic low (0 to +0.5V, 100μA max.)

disables the converter. Control voltages should be referenced to pins 3 and 4 (-Input). For best results, use a mechanical relay or open-collector logic.

When the converter is turned off, its input "standby" current will be approximately 100μA. Applying a voltage that is greater than V_{IN} to the On/Off Control pin, or applying any voltage to this pin when no input power is applied to the converter, may cause permanent damage to the converter.

TYPICAL PERFORMANCE CURVES

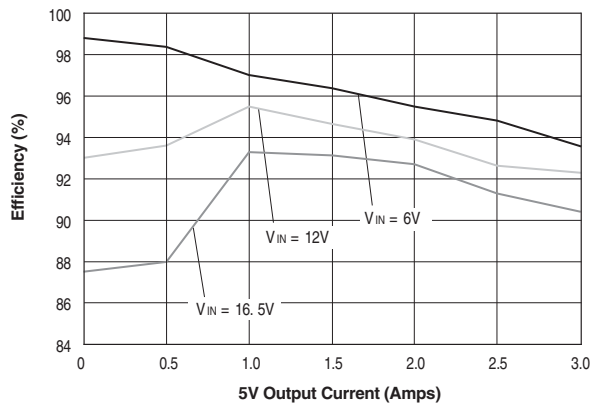

Efficiency vs. Output Current and Input Voltage (Model UNS-5/3)

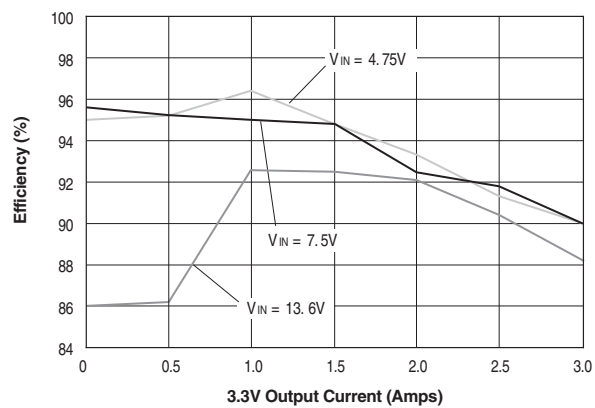

Efficiency vs. Output Current and Input Voltage (Model UNS-3.3/3)