

**NOT RECOMMENDED  
FOR NEW DESIGNS**

## DTL Series DTL35A-LC Model

Voltage-Controlled, 5 Amp  
100 Watt, Low-Compliance  
Electronic Loads

### Features

- 0-10V Input/control voltage
- 0-5A output/load current
- 0.6-30V output compliance voltage
- 0-100W output/load power
- 4MΩ Input Impedance
- 500Vdc Isolation
- ±1% accuracy under all conditions
- 200μsec full-scale step response
- 2" x 2", open-frame with baseplate package
- Operate in parallel for higher power

### Applications

- Power-supply test and characterization
- Static/dynamic power-supply burn-in
- Power-resistor substitution
- Real-time load simulation
- Capacitor discharge testing

The DTL35A-LC is an isolated (500Vdc), near-ideal ( $Z_{IN} = \geq 4M\Omega$ ), analog/voltage-controlled current sink. Its 0-5A output/load current is straightforwardly "programmed" by applying a 0-10V input. The control signal can be generated by circuits as simple as the wiper of a trimpot or as sophisticated as programmable logic controllers (PLC's) or analog-output computer I/O boards (D/A boards). The DTL35A-LC supports any combination of  $I_{OUT} = 0-5$  Amps and  $V_{OUT} = 0.6-30$  Volts. Its thermally efficient, metal package, when properly heat sunk, can dissipate output/load power up to 100 Watts.

The easy-to-use DTL35A-LC is an excellent building block for low-cost, fully flexible, power-supply (AC/DC or DC/DC) or power-component (MOSFET's, diodes, etc.) test and burn-in applications. It is accurate ( $\pm 5mA$  offset error,  $\pm 1\%$  overall accuracy), fast (200μsec full-scale step response), and capable of impressive resolution. If it is controlled with a 12-bit, 0-10V D/A converter, for example, one LSB (least significant bit) of the D/A corresponds to a 1.25mA change in the DTL35A-LC's output/load current.

The DTL35A-LC is packaged in a small (2" x 2" x 0.5"), thermally efficient open-frame package incorporating an aluminum baseplate with through-hole mounting inserts. It is powered by a single +5V supply and draws a mere 150mA.

The DTL35A-LC has an output compliance voltage of 0.6-30 Volts. Should the output/load voltage drop below the 0.6V required for proper biasing, an internal monitoring circuit activates the DTL35A-LC's output Fault line.

The DTL35A-LC and other electronic loads, controller boards, and software from DATEL are outstanding building-block components for power-supply burn-in and test systems. They are extremely reliable, cost-effective solutions that enable you to quickly configure impressively accurate systems.

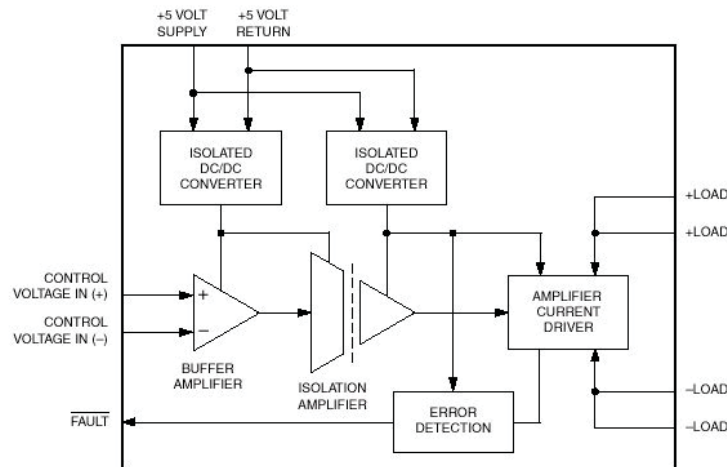
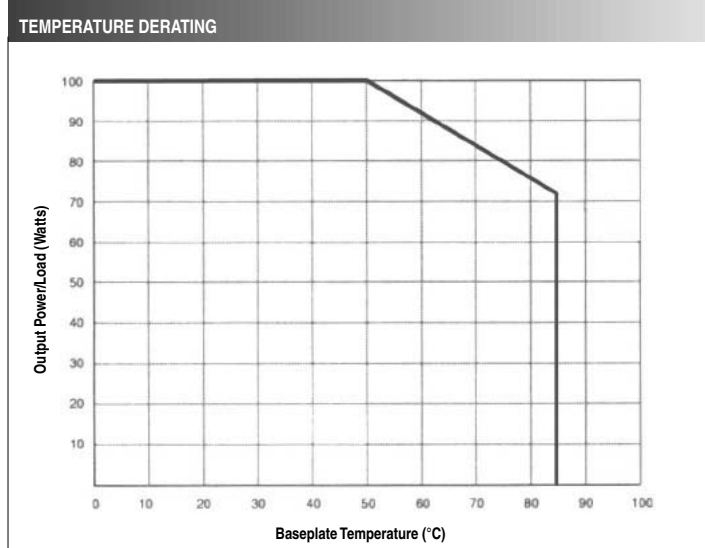
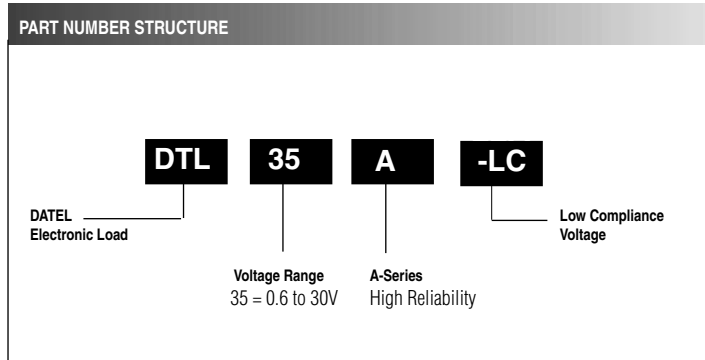

Figure 1. Simplified Schematic

**Performance Specifications and Ordering Guide** ①

Model	Input		Output				Package (Case, Pinout)
	Control Voltage (Volts)	Input Impedance (Minimum)	Current (Amps)	Resolution (mA) <sup>②</sup>	Compliance Voltage (Volts) <sup>③</sup>	Power (Watts)	
DTL35A-LC	0 to +10V	4MΩ	0-5.0	1.25	0.6-30	0-100	C24B, P51

- ① Typical at TA = +25°C with nominal +5V supply voltage, unless noted.
- ② Listed resolution (1.25mA) is for a typical application in which the DTL35A-LC is controlled by a voltage generated by a 12-bit D/A converter with a 0-10V output range. One LSB (least significant bit) of the D/A corresponds to 0.0244% (1/4096) of full scale (5.0 Amps), which equals approximately 1.25mA.
- ③ For proper operation, the unit's output/load voltage must remain within this range. Voltages greater than the listed maximum can damage the device. Voltages less than the minimum provide insufficient bias for the output stage and will result in unpredictable or no operation. See Output Compliance Voltage and the Fault Line for details.



The horizontal axis of the above chart references the temperature of the DTL35A-LC's aluminum baseplate. The device can continually dissipate up to 100 Watts if the baseplate is maintained at or below +50°C. At +25°C ambient temperature, with no heat sink or supplemental air flow, the DTL35A-LC can reliably dissipate a continuous 10 Watts.

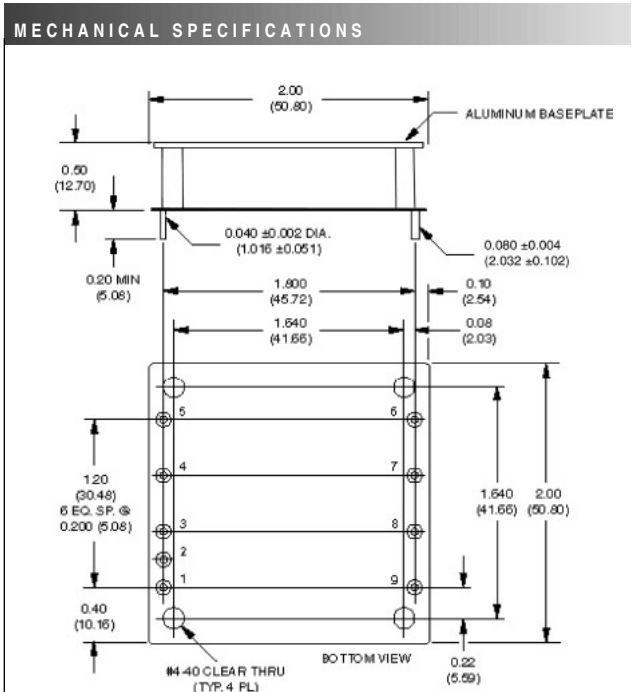

**I/O Connections**

Pin	Function P51	Pin	Function P51
1	+5 Volt Supply	6	-Load
2	+5 Volt Return	7	-Load
3	Fault	8	+Load
4	Control Voltage In (+)	9	+Load
5	Control Voltage In (-)		

Contact DATEL for Heat Sink information.

## Performance/Functional Specifications

Typical @  $T_A = +25^\circ\text{C}$  with nominal +5V supply voltage, unless noted.

Input	
Control Voltage	0-10 Volts
Impedance	4 M $\Omega$ , minimum
Output	
Transfer Function	$I_{out} \text{ (Amps)} = 0.5 V_{in} \text{ (Volts)}$
<b>Current:</b>	
Range	0-5.0 Amps
Resolution ①	0.025%FS (1.25 mA)
Offset Error ②	$\pm 5$ mA
Gain Error	$\pm 1\%$ , maximum
Absolute Accuracy ③	$\pm 1\%$ , maximum
<b>Voltage ④</b>	0.6-30 Volts
<b>Power ⑤</b>	0-100 Watts
<b>Isolation Voltage:</b>	
Analog Input to $\pm$ Load	500Vdc, minimum
+5V Power to Input or $\pm$ Load	500Vdc, minimum
Any pin to case	500Vdc, minimum
<b>Isolation Resistance</b>	100M $\Omega$ , minimum
<b>Fault Logic Levels:</b>	
Logic "1" (@ 150 $\mu$ A)	+3.5 Volts, minimum
Logic "0" (@ 1.6 mA)	+0.4 Volts, maximum
Dynamic Performance	
<b>Output Slew Rate:</b>	0.4 A/ $\mu$ sec, minimum
<b>Output Settling Time ⑥</b>	200 $\mu$ sec
<b>Dynamic Loading: ⑥</b>	
10mA to 5.0A	5 kHz
0 to 5.0A	1 kHz
Power Requirements	
<b>Power Supply Range (+Vcc, Pin1)</b>	+4.75-5.25 Volts (+5V nominal)
<b>Power Supply Current ⑥</b>	110mA typ., 150mA max.
Environmental	
<b>Operating Temperature ⑦</b>	-25 to +70 $^\circ\text{C}$
<b>Storage Temperature</b>	-40 to +85 $^\circ\text{C}$
<b>Humidity (Non-condensing)</b>	to 95%
<b>Altitude Above Sea Level</b>	10,000 feet
Physical	
<b>Dimensions</b>	2" x 2" x 0.5" (51 x 51 x 12.7 mm)
<b>Case Material</b>	Open-frame construction with aluminum baseplate
<b>Pin Material</b>	Brass, solder coated
<b>Mounting Holes</b>	Through-hole spacers, #4-40 clearance
<b>Weight</b>	1.9 ounces (54 grams)

- ① Listed resolution (1.25mA) is for a typical application in which the DTL35A-LC is controlled by a voltage generated by a 12-bit D/A converter with a 0-10V output range. One LSB (least significant bit) of the D/A corresponds to 0.0244% (1/4096) of full scale (5.0 Amps), which equals approximately 1.25mA.
- ② Offset error is defined as the current sunk/sourced by the DTL35A-LC's output, under any output-voltage conditions, when the applied control voltage is 0 Volts.
- ③ Applies over all ranges/combinations of specified output current, load voltage, output power, operating temperature and  $V_{cc}$ .
- ④ For proper operation, the DTL35A-LC's output voltage must remain within the range listed. Voltages greater than the listed maximum can damage the device. Voltages less than the listed minimum provide insufficient bias for the output stage and will result in unpredictable or no operation. See Output Compliance Voltage and Fault Line for details.
- ⑤ The DTL35A-LC can achieve its maximum output/load power only when its baseplate temperature is properly maintained. See Temperature Derating.
- ⑥ Specified for the full-scale step from 10mA to 5.0 Amps settling to  $\pm 2\%$  ( $\pm 100$ mA) of final value. A minimal loading of 10mA is recommended to achieve the fastest dynamic response.
- ⑦ Baseplate temperature. See Note 5 and Temperature Derating.

### Absolute Maximum Ratings

<b>Power Supply Voltage (+Vcc, Pin 1)</b>	-0.5 to +5.5 Volts
<b>Control Voltage In (Pin 4)</b>	-0.5 to +15 Volts
<b>Output Reverse-Polarity Protection</b>	No protection
<b>Output Overvoltage Protection</b>	No protection
<b>Output Undervoltage Protection</b>	Yes (See Fault Line)
<b>Case Temperature</b>	+85 $^\circ\text{C}$
<b>Storage Temperature</b>	-40 to +85 $^\circ\text{C}$
<b>Lead Temperature (soldering, 10 sec.)</b>	+300 $^\circ\text{C}$

These are stress ratings. Exposure of devices to any of these conditions may adversely affect long-term reliability. Proper operation under conditions other than those listed in the Performance/Functional Specifications Table is not implied.

### TECHNICAL NOTES

#### Overview

The DTL35A-LC is an analog programmable (0 to +10V control) current sink. Its output/load current range is 0 to 5.0 Amps over a compliance voltage range of 0.6 to 30 Volts and an output/load power range of 0 to 100 Watts. The device's transfer function is as follows:

$$I_{out} \text{ (Amps)} = 0.5 V_{in} \text{ (Volts)}$$

Examples: Control  $V_{in} = 1$  Volt,  $I_{out} = 0.5$  Amps  
 Control  $V_{in} = 10$  Volts,  $I_{out} = 5.0$  Amps

In a typical power-supply test or burn-in application, the output pins of the device under test (DUT) are connected to the DTL35A-LC's +Load (pins 10 and 11) and -Load (pins 8 and 9) outputs.

## TECHNICAL NOTES

**Output Compliance Voltage and the Fault Line**

For proper operation, the DTL35A-LC's output/load voltage must always be between 0.6 and 30 Volts. The device cannot be used to directly load extremely low voltages (such as 0.5V) power components or to simulate a true short circuit (0 Volts). Voltages greater than 30V can damage the device. Voltages < 0.6V will result in insufficient biasing of the output current source and consequently unpredictable or no operation. Accordingly, we have installed an internal output/load-voltage monitoring circuit. If the output/load voltage drops below 0.6V and the DTL35A-LC's output is at risk of becoming disabled, the Fault line activates.

The Fault line is an active-low function with an open-collector output (internal 10k $\Omega$  pull-up resistor to +5V). Under normal conditions, its output is high (logic "1"). Under fault conditions ( $V_{out} < 0.6V$ ), its output drops to a logic "0". There is no output/load-voltage monitoring circuit for voltages greater than 30V, and operation above 30V can damage the device.

An "offset supply" can be inserted between the DTL35A-LC's -Load output (pins 8 and 9) and the power device under test (DUT) to "translate" the DTL35A-LC's 29.4V output/load voltage range. The offset supply must have adequate current capabilities and be connected with the polarities indicated in Figure 2 below. Under no circumstances should the voltage across the DTL35A-LC's output be allowed to experience a polarity reversal.

If a 5V/5.0A offset supply is inserted as shown, the range of DUT voltages will be -4.4 to +25 Volts. Such a configuration can be used for true short-circuit testing. A mechanical relay can be used to short the outputs of the DUT while the offset supply ensures the DTL35A-LC always sees at least 5 Volts across its outputs.

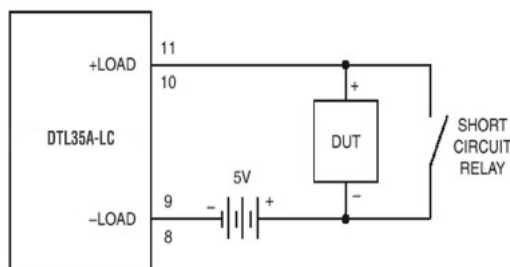

**Figure 2. An "offset Supply" Enables True Short-Circuit Testing**

**Thermal Considerations**

The DTL35A-LC can reliably handle 100W loads if its aluminum baseplate temperature is maintained at or below +50°C. With no heat sinking or auxiliary cooling, the device can only handle loads up to 10 Watts. Please refer to the Temperature Derating Curve for additional information. Datel's Electronic Load Applications Engineers can assist you in developing heat-sink solutions for your higher-power DTL35A-LC applications. Please contact us for details and concerning our DTL-HS100D12 heat sink.

**Constant Resistance Application**

The DTL35A-LC operates as a constant current electronic load in its typical configuration. A constant resistance mode of operation can be achieved as follows:

The DTL35A-LC has a high impedance isolated analog input, that allows the analog inputs to be connected directly across the load. The DTL35A-LC sinks 5.0 amps for a 10V full scale input or  $I = 0.5 \times V_{IN}$ . If you make  $V_{IN} = V_{LOAD}$  (the voltage across the load), then  $R = V_{LOAD}/I = V_{LOAD} / (0.5 \times V_{LOAD}) = 2$  Ohms. Consequently, the load looks like a 2 Ohm resistor.

Furthermore, if you make  $V_{IN} = k \times V_{LOAD}$  by connecting a potentiometer or resistive divider across the load, then  $R = V_{LOAD} / (0.5 \times k \times V_{LOAD}) = 2/k$  so adjusting the potentiometer will give you an adjustable power resistor e.g. at  $k = 2$ , then  $R = 1$  Ohm,  $k = 1$  then  $R = 2$  Ohms, etc. The only limitation that you must observe is the maximum load voltage (30V) and 100 watt power dissipation. A multiplying digital-to-analog converter, or a digital potentiometer could be utilized to make a programmable resistance.



ISO-9001 REGISTERED

DS-0xxx 6/01

DATEL, Inc. 11 Cabot Boulevard, Mansfield, MA 02048-1151  
Tel: (508) 339-3000 (800) 233-2765 Fax: (508) 339-6356  
Internet: www.datel.com Email: sales@datel.com

DATEL (UK) LTD. Tadley, England Tel: (01256)-880444  
DATEL S.A.R.L. Montigny Le Bretonneux, France Tel: 01-34-60-01-01  
DATEL GmbH München, Germany Tel: 89-544334-0  
DATEL KK Tokyo, Japan Tel: 3-3779-1031, Osaka Tel: 6-354-2025

DATEL makes no representation that the use of its products in the circuits described herein, or the use of other technical information contained herein, will not infringe upon existing or future patent rights. The descriptions contained herein do not imply the granting of licenses to make, use, or sell equipment constructed in accordance therewith. Specifications are subject to change without notice. The DATEL logo is a registered DATEL, Inc. trademark.