

Model: VCN75-018V

Features:

- Supports DDR2 Memory
- Programmable
- Soft Start Circuit
- Over-Voltage Protection
- Over-Current Protection
- Remote Sense
- Power Good Signal
- Output Enable
- High Efficiency
- "1U" Height

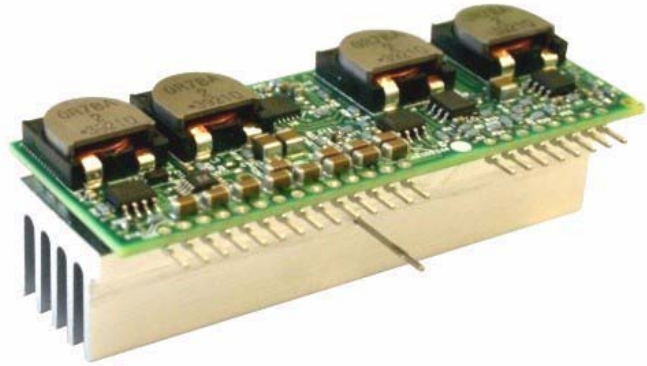

This product is not fuse protected. User is responsible for providing system protection. Consult factory for application information.

Table 1:

Input Characteristics	Notes & Conditions*	Min.	Typ.	Max.	Units
Input Voltage Operating Range		10.8	12.0	13.2	Vdc
Maximum Input Current	1.95Vout @ 75A/10.8Vin		16.0		A
No-Load Input Current				300	mA
Disabled Input Current				50	mA
Input Reflected Ripple Current	1.95Vout @ 75A/13.2Vin		200		mA p-p
Required External Input Capacitor	OSCON Type	270			µF

Table 2:

Output Characteristics	Notes & Conditions*	Min.	Typ.	Max.	Units
Output Voltage Set Point	Programmable	1.7		2.5	Vdc
Output Line Regulation				±0.5	%
Output Load Regulation				±0.5	%
Output Voltage Ripple & Noise	20MHz Bandwidth		50		mV p-p
Output Current Operating Range		0		75	A
Efficiency	100% Load 12Vin, 1.8Vout		85		%
Turn-On Time				10	mS
Remote Sense Compensation				10	%Vo nom
Output Voltage Trim Range		1.7		2.5	V
Required External Output Capacitance		1K		8K	µF

1150 Eglinton Avenue East
Toronto, Ontario M3C 1H7
1-866-740-1232

www.cdtechno-cps.com

4607 S.E. International Way
Milwaukie, Oregon 97222
1-971-206-2800

Table 3:

Protection Characteristics	Notes & Conditions*	Min.	Typ.	Max.	Units
Output Current Limit Inception	Hiccup Mode		100		A
Over Voltage Shutdown	Latching		115		%Vnom
Fusing	Unit is not fused.				

Table 4:

General Specifications	Notes & Conditions*	Min.	Typ.	Max.	Units
Enable	LOW = Disable			0.8	Vdc
	HIGH = Enable	1.7			Vdc
Storage Temperature		-40		70	°C
Operating Temperature		0		50	°C
Material Flammability	UL 94V-0				
MTBF	Calculated (RAC PRISM @ 50°C)		785		x10 ³ Hrs
Switching Frequency	Per Phase		200		KHz
Dimensions	3.0"L x 1.05"W x 1.1"H				

* Note: Vin = 12Vdc, Ta = 25°C, Airflow = 300LFM unless otherwise noted. Specifications subject to change without notice

Programming the Output

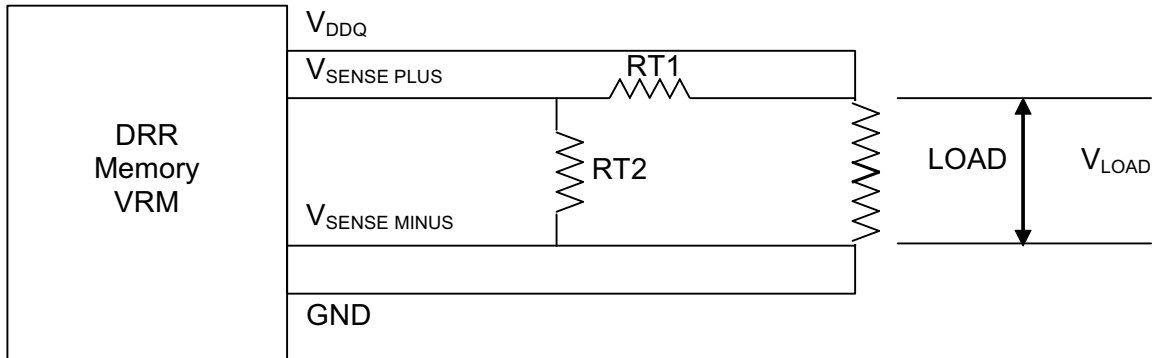

Table 5:

Vo* (Vo)	RT1 (ohm)	RT2 (ohm)
1.7	499	3261
1.75	499	2670
1.8	499	2260
1.85	499	1959
1.9	499	1729
1.95	499	1547
2	499	1400
2.1	499	1176
2.2	499	1014
2.3	499	891
2.4	499	795
2.5	499	717

*Vo measured at the load side

Mechanical Information

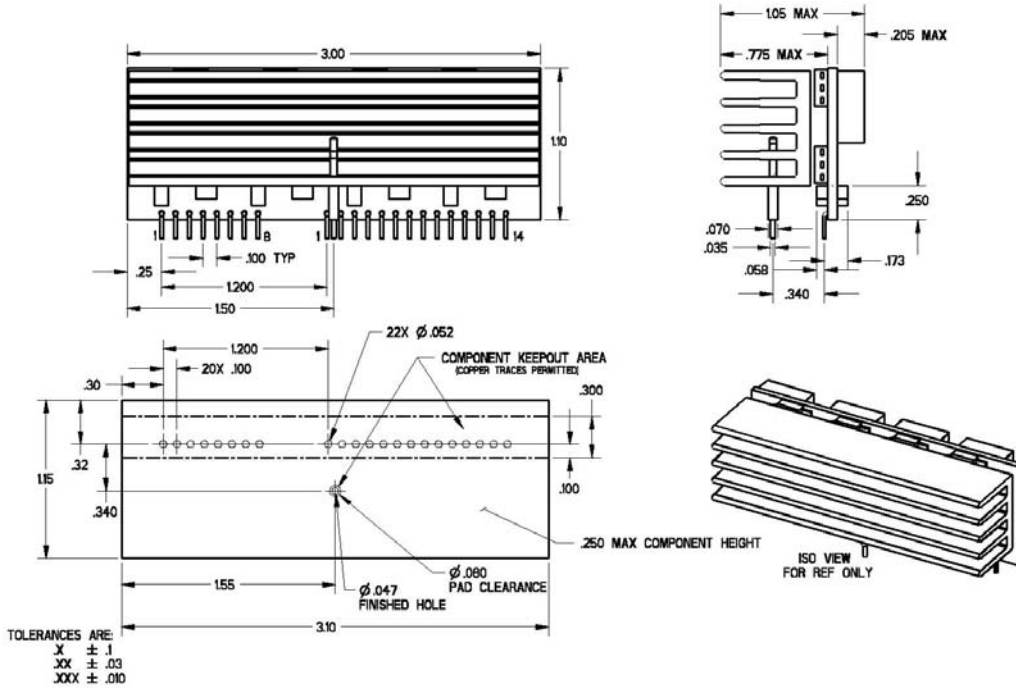
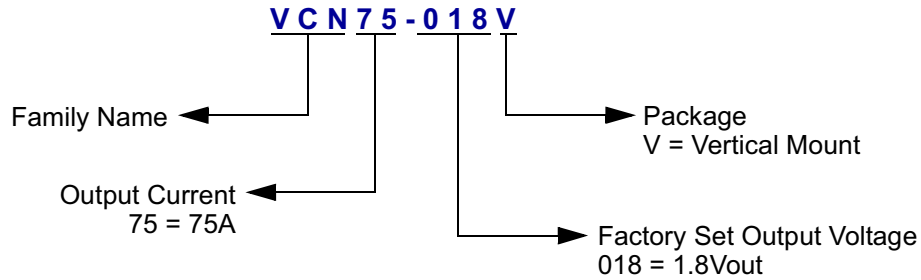

Table 6:

Connector J1 Pin Name	Function	Connector J2 Pin Name	Function
1	Power Good	1	GND
2	Output Enable	2	Vo
3	Sense-	3	GND
4	Sense+	4	Vo
5	12Vin	5	GND
6	12Vin	6	Vo
7	GND	7	GND
8	GND	8	Vo
		9	GND
		10	Vo
		11	GND
		12	Vo
		13	GND
		14	Vo

Ordering Information



C&D Technologies, Inc. reserves the right to alter or improve the specification, internal design or manufacturing process at any time, without notice. Please check with your supplier or visit our website to ensure that you have the current and complete specification for your product before use.

© C&D Technologies, Inc. 2004

No part of this publication may be copied, transmitted, or stored in a retrieval system or reproduced in any way including, but not limited to, photography, photocopy, magnetic or other recording means, without prior written permission from C&D Technologies, Inc.

Instructions for use are available from: www.cdtechno-cps.com

**1150 Eglinton Avenue East
Toronto, Ontario M3C 1H7
1-866-740-1232**

www.cdtechno-cps.com

**4607 S.E. International Way
Milwaukie, Oregon 97222
1-971-206-2800**