

CONTENTS

- 1 Impedance matching transformers
- 2 Selection procedure for matching transformers
- 3 Selection strategy
- 4 Transformers for thyristor drives
- 5 Transformer applications in analogue and digital circuits
- 6 Digital circuits
- 7 Design examples
- 8 Control circuits
- 9 Switching power supplies
- 10 3 phase motor controller
- 11 EMC design considerations
- 12 Common mode chokes

1. IMPEDANCE MATCHING TRANSFORMERS

Matching is required to ensure maximum power transfer from the source to the load (see figure 1).

In the real world the matching transformer will present its own shunt impedance to the source (see figure 2).

The magnitude of this impedance will depend on the primary inductance and the frequency of operation. This should be large compared with the source impedance. A safety factor of 5 should be sufficient for most applications. If too high a primary inductance is chosen, the parasitic components (shunt capacitance, leakage inductance etc) conspire to reduce the high-frequency performance of the circuit.

Figure 1: Ideal Matching

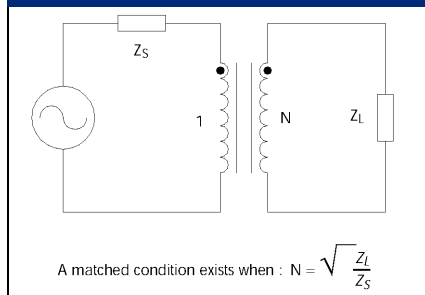
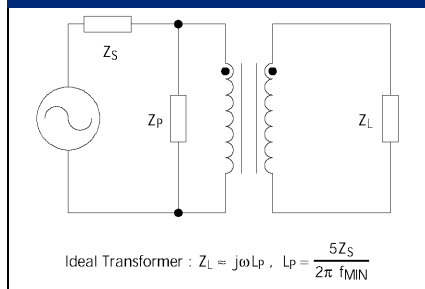

Figure 2: Ideal Shunt Impedance



2. SELECTION PROCEDURE FOR MATCHING TRANSFORMERS

It is necessary to check the pulse distortion when selecting the transformer. There is a maximum area of pulse which a given transformer can transmit; this is known as the Et constant. Figure 3 indicates how this may be estimated from the known pulse shape. It is worth noting that if no upper limit can be

put on the value of T_{PW} then it will not be possible to use a transformer in this application - transformers do not work with DC! If too low an Et constant is chosen then the full pulse width will not be transmitted and the transformer will cause excessive loading to the line due to saturation. Conversely, too high an Et constant will bring attendant high parasitic capacitance and inductance which will cause a poor rise time.

The other distortion which should be checked is droop. Figure 3 shows the definition of droop and its relationship with primary inductance. R is the parallel combination of the source and reflected load impedance; for the matched case this will be half the source impedance. Unless otherwise specified a droop of 10% can usually be tolerated. Here again excessive inductance brings increased parasitics and their attendant problems. From the preceding discussion we can propose a strategy which should enable us to select the correct component in the majority of applications. The approximations made mean that the strategy has its limitations but the errors are usually negligible.

3. SELECTION STRATEGY

1. Identify Z_S & Z_L
2. Identify (minimum) operating frequency (f_{MIN})
3. Identify maximum pulse width (T_{PW}) and voltage (V_p)
4. Calculate turns ratio from: $N = \sqrt{\frac{Z_L}{Z_S}}$
5. Calculate minimum primary inductance from: $L_{P_{MIN}} = \frac{2.5 Z_S}{2 f_{MIN}}$
6. Calculate minimum ET constant from: $E_{T_{MIN}} = V_p T_{PW}$
7. Check droop is acceptable (probably <10%) from:
 $D = 1 - \exp - \frac{Z_S T_{PW}}{2L_p}$
8. If droop is unacceptable re-calculate L_p from: $L_p = - \frac{Z_S T_{PW}}{2LP}$
9. Select the device that meets the above specification with the lowest values of leakage inductance and interwinding capacitance.

Figure 3: Pulse Width and Droop

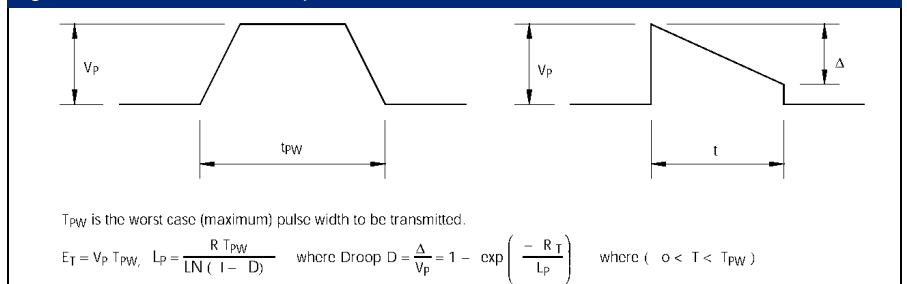

TRANSFORMERS

Application Notes

4. TRANSFORMERS FOR THYRISTOR DRIVES

Transformers are used in thyristor drives to provide isolation of control circuitry and voltage/current transformation. In order for the thyristor to switch on, the gate must be held high until the current in the thyristor exceeds the holding current of the device (see figure 4). This time depends on the device itself and the load characteristics. A resistive load will have a fast current rise time and hence require a narrower pulse than would an inductive load. Unfortunately the majority of applications are for motor drives and it is often difficult to define a figure for maximum pulse duration. It is also important to ensure

irreplaceable using other technologies, such as bi-directional capability, high galvanic isolation and the ability to transfer power as well as data across the isolation barrier, all from a low cost part.

6. DIGITAL CIRCUITS

The bi-directional capability of wound transformers is most often found in computer and public telephone networks where isolation is also required. There are a wide range of network isolators available from C&D Technologies (NCL) for most popular local area networks (Ethernet, Token Ring etc) that provide some form of signal filtering as well as bi-directional communication and isolation. The isolators are designed to match

the line impedance of the cabling system used on the line side and the output termination of the interface IC at the digital termination side (DTE). Many of the pulse transformers available from C&D Technologies (NCL) are suitable for other interface standards, such as IBM 3270 (see figure 6), as well as offering solutions to more exotic networking systems.

In digital audio transmission systems isolation transformers are required to provide good line-to-system matching, improving the balance of transmit and receiver circuits, and reduce common mode noise and EMI. The DA100 Series series offer AES/EBU standards compatible transformers, the DA100 Series is designed to meet AES3 - 1995 / IEC958 specification for digital audio transmission and compatible with the crystal semiconductor CS 8401/2 chip sets.

The electrical parameters for the digital audio interface (see figure 7) allow transmission up to a few hundred metres, based on IEC958 S/PDIF. Although the above discussion is based on the professional audio standards, by suitable change to the terminating circuits, the design can also be used in a 75 consumer audio system.

Figure 4: Thyristor Trigger Pulse

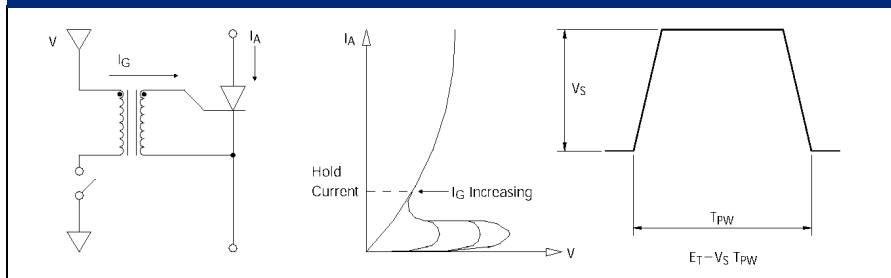
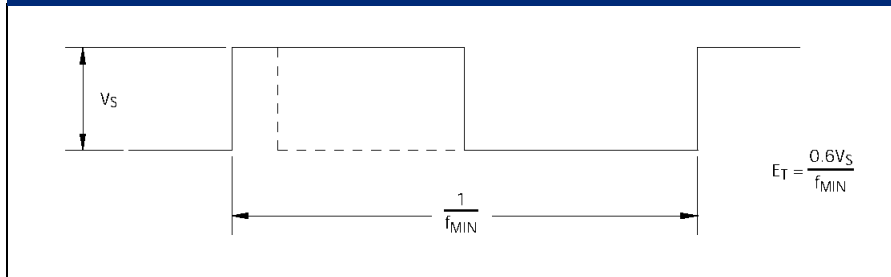

Figure 5 : Mark to Space Ratio



that the thyristor does not turn on too slowly.

This leads to local 'hot spots' in the device and premature device failure. This requirement means that the transformer should have as low a leakage inductance as possible. For applications where pulse-width modulation (PWM) techniques are to be employed it should be remembered that it is very difficult, if not impossible, to work pulse transformers at more than 60% mark:space ratio. The reason for this is that the transformer requires time to reset between pulses. If the maximum mark:space ratio is defined along with the operating frequency, the required E_T constant can be readily defined (see figure 5).

5. TRANSFORMER APPLICATIONS IN ANALOGUE AND DIGITAL CIRCUITS

Although often overlooked, the use of transformers in modern electronic equipment is continually expanding. This simple passive element has many features that are

7. DESIGN EXAMPLES:

1. PASSING 50% DUTY CYCLE SIGNAL THROUGH ISOLATING TRANSFORMERS

There are situations when a 50% duty cycle signal can pass through a transformer without problems, providing there is a negative transition to completely de-magnetise the core. If the core is not wholly demagnetised a build up of energy can occur and eventually the pulse can no longer pass through the transformer. In general low frequencies are

Figure 6: Typical Applications for IBM 3270 Interface

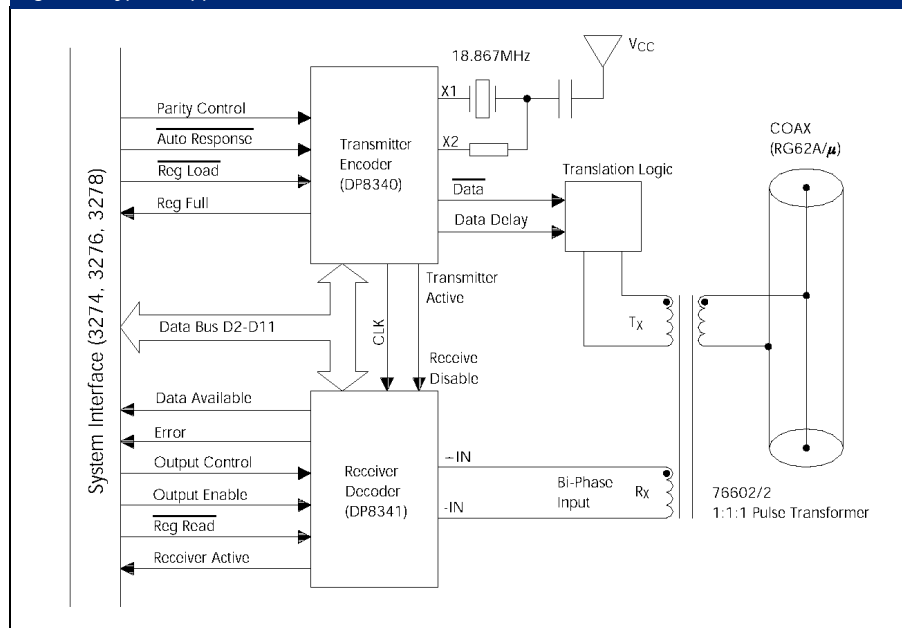

Figure 7: Digital Audio Transmission System

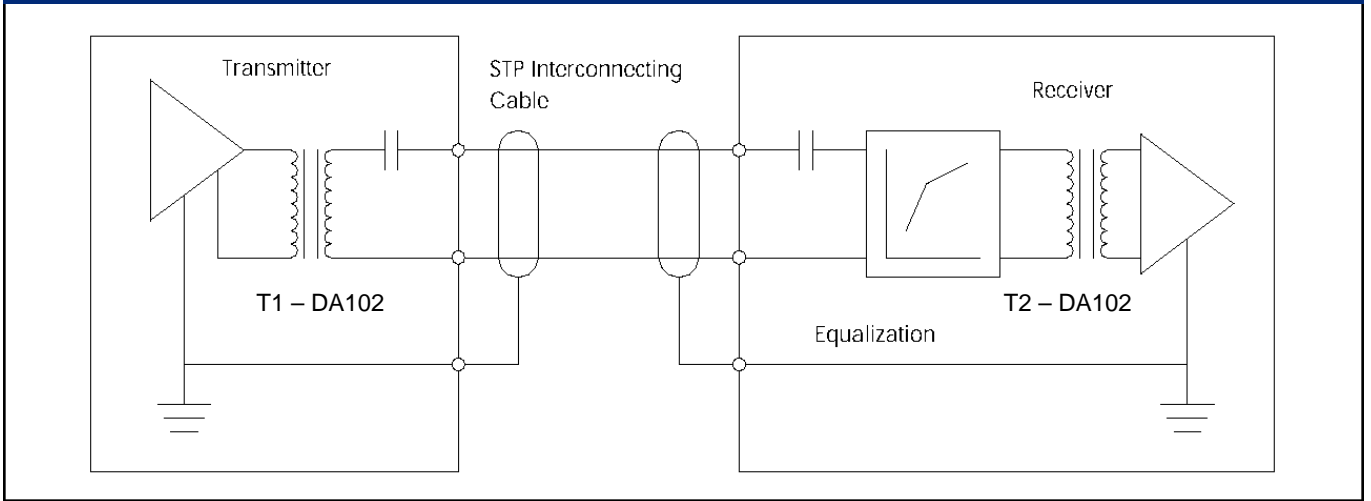

Figure 8: Pass 50WF

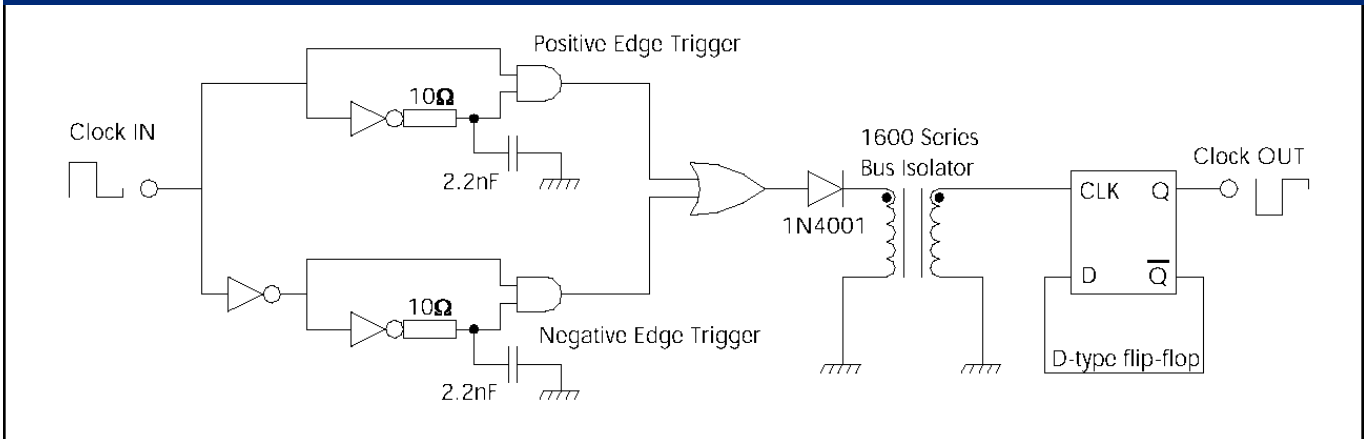
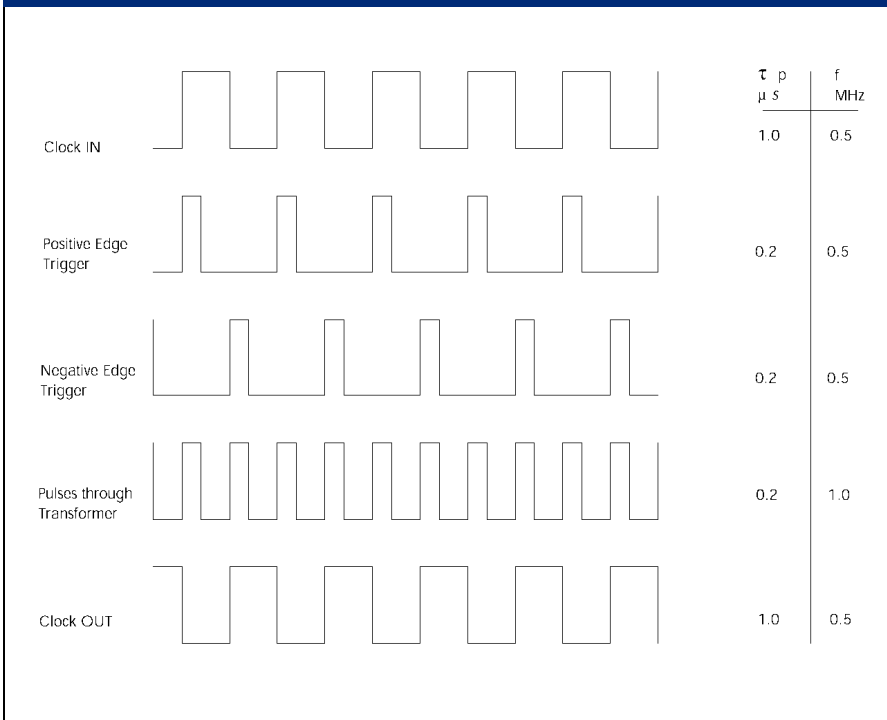

Figure 9 Pass 50CC



not a problem as the core is only magnetised for a small part of the pulse period. High frequencies, typically those used in microprocessor timing and digital logic circuits, can cause saturation problems in the core due to magnetic energy build up, especially when transitions are between zero and a positive voltage.

The circuit shown in figure 8 overcomes the problem of passing 50% duty cycle signals through an isolating transformer by sending narrow edge triggered pulses through the transformer, and regenerating the 50% signal on the other side of the isolation barrier. The circuit consists of two edge triggers; one positive edge and one negative edge, an OR gate logic driver and a D-type flip-flop divider. The edge detectors produce narrow pulses whose pulse width can be determined by the selection of appropriate R and C values ($2 RC$). The narrow pulses are combined at the OR gate to produce a frequency doubled signal with a narrow pulse width. Pulse widths of less than 50% allow the core to easily desaturate during the 'off' cycle. The 50% duty cycle is regenerated using a D-type flip-flop frequency divider on the other side of the isolation barrier.

Figure 13: Fully Isolated Half Bridge Drive

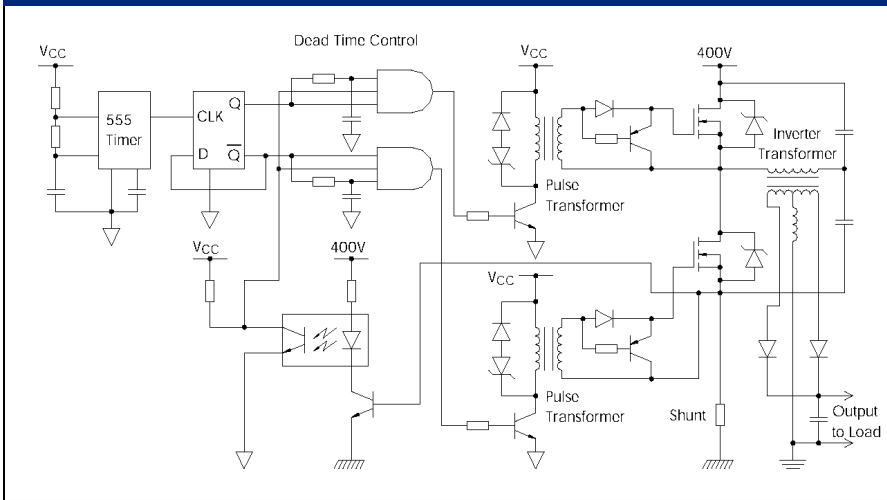

9. SWITCHING POWER SUPPLIES

High efficiency power transfer requires high switching frequencies, hence transformers designed for 50Hz or 60Hz mains are not suitable. There is a range of controller IC's now available off-the-shelf to enable high efficiency switch mode power supplies to be easily constructed. The corresponding transformers are designed to match the operating frequency of these parts to produce high efficiency SMPS designs.

At C&D Technologies (NCL) we offer a custom design service for SMPS designs, since we have extensive knowledge of many controller IC's ourselves. Designs are usually made on toroids to enable a low EMI magnetics for operating frequencies of several hundred kHz. Generally higher

frequencies are accommodated with RM or pot core designs, suitable for supplies operating in the MHz region.

An example of one transformer for this application that has become a standard product is the 78250 part for use with the Maxim 250/251 chip set to produce an isolated RS232 interface. The transformer provides the power transfer and voltage step-up as well as maintaining the isolation barrier (see figure 14).

10. 3 PHASE MOTOR CONTROLLER

The advantage of using pulse transformers in a 3 phase motor controller application (see figure 15) are that a higher isolation is available compared with IGBT devices and

Figure 14: Isolated RS232 Interface

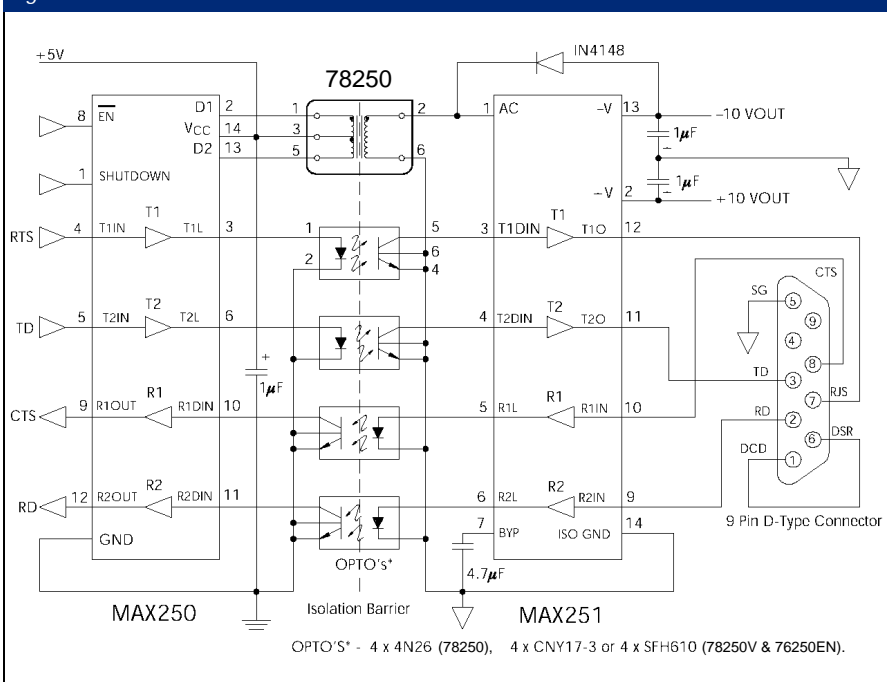

there is an inherent overload protection should any phase controller fail (devices are locked off). The isolation barrier between the switching controller system and the motor supply also reduces noise from either system interfering with other controller functions. Further noise and interference suppression can be obtained by isolating the control bus, either by using logic isolators or a local area control network (see the C&D Technologies (NCL) range of Network and Interface Products for more details).

11. EMC DESIGN CONSIDERATIONS

EC regulations regarding electromagnetic compatibility (EMC) effect many aspects of circuit and system design. However, there are many considerations that can be applied generally to reduce both the emissions from and susceptibility to electromagnetic interfaces (EMI).

There are many areas where the use of transformers in decoupling, isolating and filtering applications will help. As a manufacturer C&D Technologies (NCL) is committed to minimising emissions from its own components and to helping its customers achieve EMC compliance by correct component choice and design. To this end we have compiled the following list of general design considerations:

- reduce high frequency (particularly radio frequency) loops in supply lines
- decouple supply lines at local boundaries (use RCL filters with Q = 2)
- use low pass filters on signal lines to reduce bandwidth to signal minimum
- keep return and feed loops close on wide bandwidth signal lines
- terminate lines carrying HF or RF signals correctly (this minimises reflection, ringing and overshoot)
- avoid slit apertures in pcb layout, particularly in ground planes or near current paths
- use common mode chokes between current carrying and signal lines to increase coupling and cancel stray fields
- use discrete components and filters where possible
- ensure filtering of cables and over voltage protection (this is especially true of cabling that is external to the system, if possible all external cabling should be isolated at the equipment boundary)
- isolate individual systems where possible (especially analogue and digital systems, on both power supply and signal lines)
- if available, use shielding on fast switching circuits, mains power supply components and low power circuitry.

TRANSFORMERS

Application Notes

In general, keeping the bandwidth of all parts of the system to a minimum and isolating circuits where possible reduces susceptibility and emissions.

Transformers can be used for both correct termination and filtering of signal and power lines.

12. COMMON MODE CHOKES

Many of the 1:1 ratio transformers described in this data book can be utilised as either common or differential mode chokes. The 766 series are particularly well suited to signal lines, where very low DC resistance and good coupling provide excellent common mode properties. C&D Technologies (NCL) can design a common mode choke for either power or signal applications to a customer's requirement and are always open to suggestions. We may even already have a design that is suitable for the application being considered.

Figure 15: 3 Phase Motor Controller

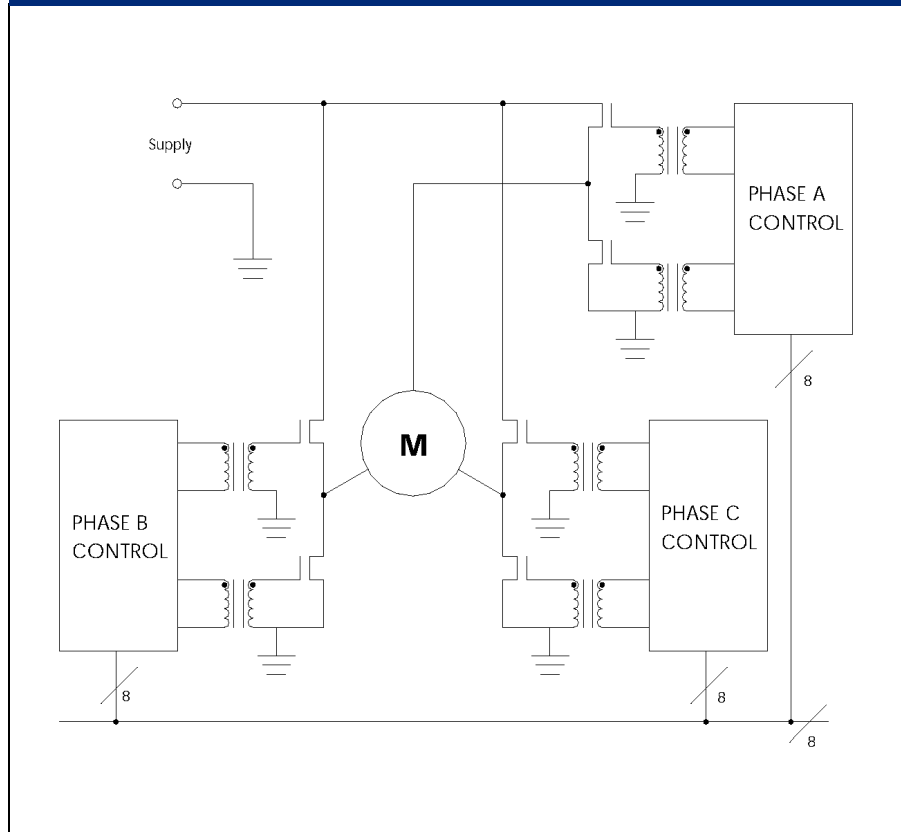

C&D Technologies (NCL) Limited reserve the right to alter or improve the specification, internal design or manufacturing process at any time, without notice. Please check with your supplier or visit our web site to ensure that you have the current and complete specification for your product before use.

© C&D Technologies (NCL) Limited 2000

AN008.1

No part of this publication may be copied, transmitted or stored in a retrieval system or reproduced in any way including, but not limited to, photography, photocopy, magnetic or other recording means, without prior written permission from C&D Technologies (NCL) Limited.

Instructions for use are available from www.dc-dc.com

C&D Technologies (NCL) Ltd
Tanners Drive, Blakelands North
Milton Keynes MK14 5BU, England
Tel: +44 (0)1908 615232
Fax: +44 (0)1908 617545
email: info@cdtechno-ncl.com

[www: http://www.dc-dc.com](http://www.dc-dc.com)

C&D Technologies (NCL), Inc.
8917 Glenwood Avenue, Raleigh
NC 27612, USA
Tel: +1 (919) 571-9405
Fax: +1 (919) 571-9262
email: info@us.cdtechno-ncl.com

 **TECHNOLOGIES**
Power Solutions