

FEATURES

- 200ns Maximum acquisition time
- $\pm 0.01\%$ Accuracy
- 100ns Maximum sample-hold settling time
- 74dB Feedthrough attenuation
- $\pm 50\text{ps}$ Aperture uncertainty
- Industry standard

PRODUCT OVERVIEW

DATEL's SHM-4860 is a high-speed, highly accurate sample hold amplifier designed for precision, high-speed analog signal processing applications. Manufactured using modern, high quality hybrid technology, the SHM-4860 features excellent dynamic specifications including a maximum acquisition time of only 200ns for a 10V step to $\pm 0.01\%$. Sample-to-hold settling time, to $\pm 0.01\%$ accuracy, is 100ns maximum with an aperture uncertainty of $\pm 50\text{ps}$.

The SHM-4860 is a complete sample-hold circuit, containing a precision MOS hold capacitor and a MOSFET switching configuration which results in faster switching and better feedthrough attenuation. Additionally, a FET-input amplifier design allows faster acquisition and settling times while maintaining a considerably lower droop rate.

SIMPLIFIED SCHEMATIC

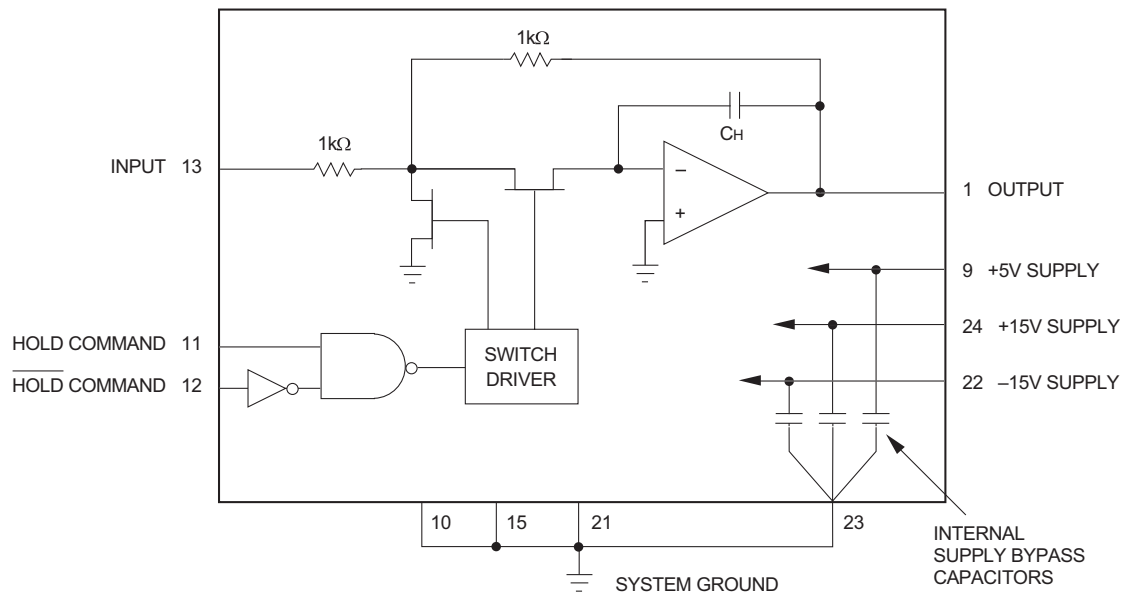

Figure 1. Functional Block Diagram



ORDERING GUIDE SUMMARY	
Model Number	Operating Temperature Range
SHM-4860MC	0 to +70°C
SHM-4860MM	-55 to +125°C
SHM-4860/883	-55 to +125°C

INPUT/OUTPUT CONNECTIONS			
PIN	FUNCTION	PIN	FUNCTION
1	OUTPUT	24	+15V SUPPLY
2	N.C.	23	GROUND
3	N.C.	22	-15V SUPPLY
4	N.C.	21	GROUND
5	N.C.	20	N.C.
6	N.C.	19	N.C.
7	N.C.	18	N.C.
8	N.C.	17	N.C.
9	+5V SUPPLY	16	N.C.
10	GROUND	15	GROUND
11	HOLD COMMAND	14	N.C.
12	HOLD COMMAND	13	INPUT

MECHANICAL SPECIFICATIONS

24-PIN DDIP

Dimension Tolerances (unless otherwise indicated):
 2 place decimal (.XX) ± 0.010 (± 0.254)
 3 place decimal (.XXX) ± 0.005 (± 0.127)

Lead Material: Kovar alloy

Lead Finish: 50 microinches (minimum) gold plating
 over 100 microinches (nominal) nickel plating

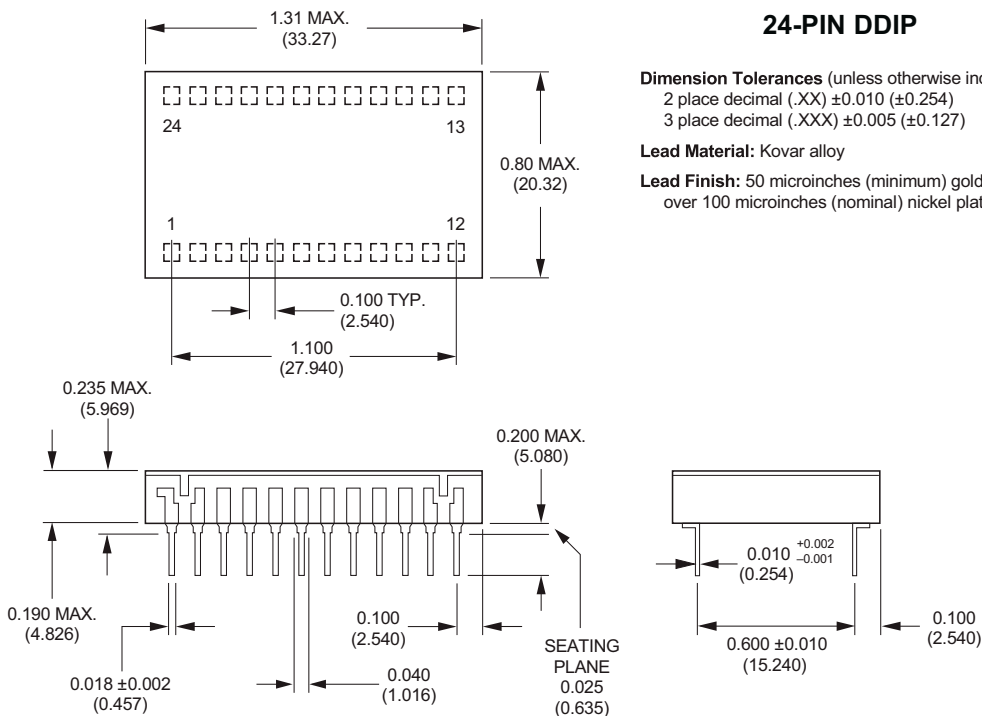

Dimensions in inches (mm)

ABSOLUTE MAXIMUM RATINGS	
$\pm 15V$ Supply Voltages, Pins 24, 22	$\pm 18V$
+5V Supply Voltage, Pin 9	-0.5V to +7V
Analog Input, Pin 13 ①	$\pm 18V$
Digital Inputs, Pins 11, 12	-0.5V to +7V
Output Current ②	$\pm 65mA$

Functional Specifications

(Typical at +25°C with $\pm 15V$ and +5V supplies unless otherwise noted.)

ANALOG INPUT/OUTPUT				
	MIN.	TYP.	MAX.	UNITS
Input/Output Voltage Range ①	± 10.25	± 11.25	—	V
Input Impedance	—	1	—	k Ω
Output Current ②	—	—	± 40	mA
Output Impedance	—	0.1	—	Ω
Maximum Capacitive Load	—	250	—	pF

DIGITAL INPUT				
	MIN.	TYP.	MAX.	UNITS
Input Logic Level				
Logic "1"	+2.0	—	+5.0	V
Logic "0"	0	—	+0.8	V
Loading				
Logic "1"	—	—	+40	μA
Logic "0"	—	—	-1.6	mA

TRANSFER CHARACTERISTICS				
	MIN.	TYP.	MAX.	UNITS
Gain	—	-1	—	V/V
Gain Accuracy	—	± 0.05	± 0.1	%
Gain Linearity Error ③	—	± 0.005	± 0.01	%FS
Sample-Mode Offset Voltage	—	± 0.5	± 5	mV
Sample-to-Hold Offset Error ④ (Pedestal)	—	± 2.5	± 20	mV
Gain Tempco (Drift)	—	± 0.5	± 5	ppm/°C
Sample-Mode Offset Drift	—	± 3	± 15	⑤
Sample-to-Hold Offset Drift	—	± 4	—	⑤

DYNAMIC CHARACTERISTICS				
Acquisition Time				
	MIN.	TYP.	MAX.	UNITS
10V to $\pm 0.01\%$ FS	—	160	200	ns
10V to $\pm 0.1\%$ FS	—	100	170	ns
10V to $\pm 1\%$ FS	—	90	—	ns
1V to $\pm 1\%$ FS	—	75	—	ns
Sample-to-Hold Settling Time				
10V to $\pm 0.01\%$ FS	—	60	100	ns
10V to $\pm 0.1\%$ FS	—	40	—	ns
Sample-to-Hold Transient	—	180	—	mV p-p

DYNAMIC CHARACTERISTICS, Continued				
	MIN.	TYP.	MAX.	UNITS
Aperture Delay Time	—	6	—	ns
Aperture Uncertainty (Jitter)	—	± 50	—	ps
Output Slew Rate	—	± 300	—	$\mu V/\mu s$
Output Slew Rate	—	± 300	—	$\mu V/\mu s$
Small Signal Bandwidth (-3dB)	—	16	—	MHz
Droop: +25°C	—	± 0.5	± 5	$\mu V/\mu s$
	+70°C	—	± 15	$\mu V/\mu s$
	+125°C	—	± 1.2	mV/ μs
Feedthrough Attenuation	—	74	—	dB

Overload Recovery Time				
	MIN.	TYP.	MAX.	UNITS
Positive	—	200	—	ns
Negative	—	700	—	ns

POWER REQUIREMENTS				
	MIN.	TYP.	MAX.	UNITS
Voltage Range: $\pm 15V$ Supplies	—	± 3	—	%
	+5V Supply	—	± 5	%
Power Supply Rejection Ratio	—	± 0.5	—	mV/V

Quiescent Current Drain				
	MIN.	TYP.	MAX.	UNITS
+15V Supply	—	+21	+25	mA
-15V Supply	—	-22	-25	mA
+5V Supply	—	+17	+25	mA
Power Consumption	—	730	875	mW

PHYSICAL/ENVIRONMENTAL	
Operating Temperature Ranges	
SHM-4860MC	0 to +70°C (ambient)
SHM-4860MM, 883	-55 to +125°C (case)
Storage Temperature Range	-65 to +150°C
Package Type	24-pin ceramic DDIP

Footnotes:

- ① Input signal should not exceed the supply voltage.
- ② The SHM-4860's output is current limited at approximately $\pm 65mA$. The device can withstand a sustained short to ground. However, shorts from the output to either supply will cause permanent damage. For normal operation, the load current should not exceed $\pm 40mA$.
- ③ Full Scale (FS) = 10V. Full Scale Range (FSR) = 20V.
- ④ Sample-to-Hold Offset Error (Pedestal) is constant regardless of input/output level.
- ⑤ Units are ppm of FSR/°C.

TECHNICAL NOTES

1. All ground pins (10, 15, 21, 23) should be tied together and connected to system analog ground as close to the package as possible. It is recommended to use a ground plane under the device and solder all four ground pins directly to it. Care must be taken to ensure that no ground potentials can exist between Pin 10 and the other ground pins.
2. Although the power supply pins (9, 22, 24) are internally bypassed to ground with 0.01 μF ceramic capacitors, additional external 0.1 μF to 1 μF tantalum bypass capacitors may be required in critical applications.
3. A logic "0" on the HOLD COMMAND input (Pin 11), or a logic "1" on the HOLD COMMAND input (Pin 12), will put the device in the sample mode. In this mode, the device acts as an inverting unity-gain amplifier, and its output will track its input. A logic "1" on Pin 11 (logic "0" on Pin 12) will put the device in the hold mode, and the output will be held constant at the last input level present when the hold command was given. If the HOLD COMMAND input (Pin 11) is used to control the device, Pin 12 must be tied to digital ground. If HOLD COMMAND input (Pin 12) is used to control the device, Pin 11 must be tied to +5V.
4. The maximum capacitive load to avoid oscillation is typically 250pF. Recommended resistive load is 500 Ω , although values as low as 250 Ω may be used. Acquisition and sample-to-hold settling times are relatively unaffected by resistive loads down to 250 Ω and capacitive loads up to 50pF. However, higher capacitances will affect both acquisition and settling time.

