

Typical unit

FEATURES

- 35 nSec maximum acquisition time to 0.01%
- 30 nSec maximum hold-mode settling to 0.01%
- 1 pSec aperture uncertainty
- 150 MHz small-signal bandwidth
- 545 mW power dissipation
- Small 14-pin DIP package
- CMOS control signal

PRODUCT OVERVIEW

The SHM-43 sample-hold utilizes a proprietary architecture in delivering an acquisition time of 35 nanoseconds maximum to 0.01% and 20 nanoseconds maximum to 0.1% accuracy.

Operation requires +15V and ±5V supplies and the analog input range is ±2V. Packaged in a small 14-pin DIP, the SHM-43 offers a CMOS compatible sample command while dissipating just 545 milliwatts.

The SHM-43 has been designed for applications that demand fast acquisition times (25 nS,

±0.01%), fast hold mode settling (20nS, ±0.01%), wide bandwidth, and the ability to drive resistive (100Ω), and capacitive (50 pF) loads with no compromise in performance. These features make the SHM-43 an ideal choice for driving flash A/D converters in applications such as radar and communications.

Two temperature ranges are offered: the commercial 0 to +70 °C and military -55 to +125 °C.

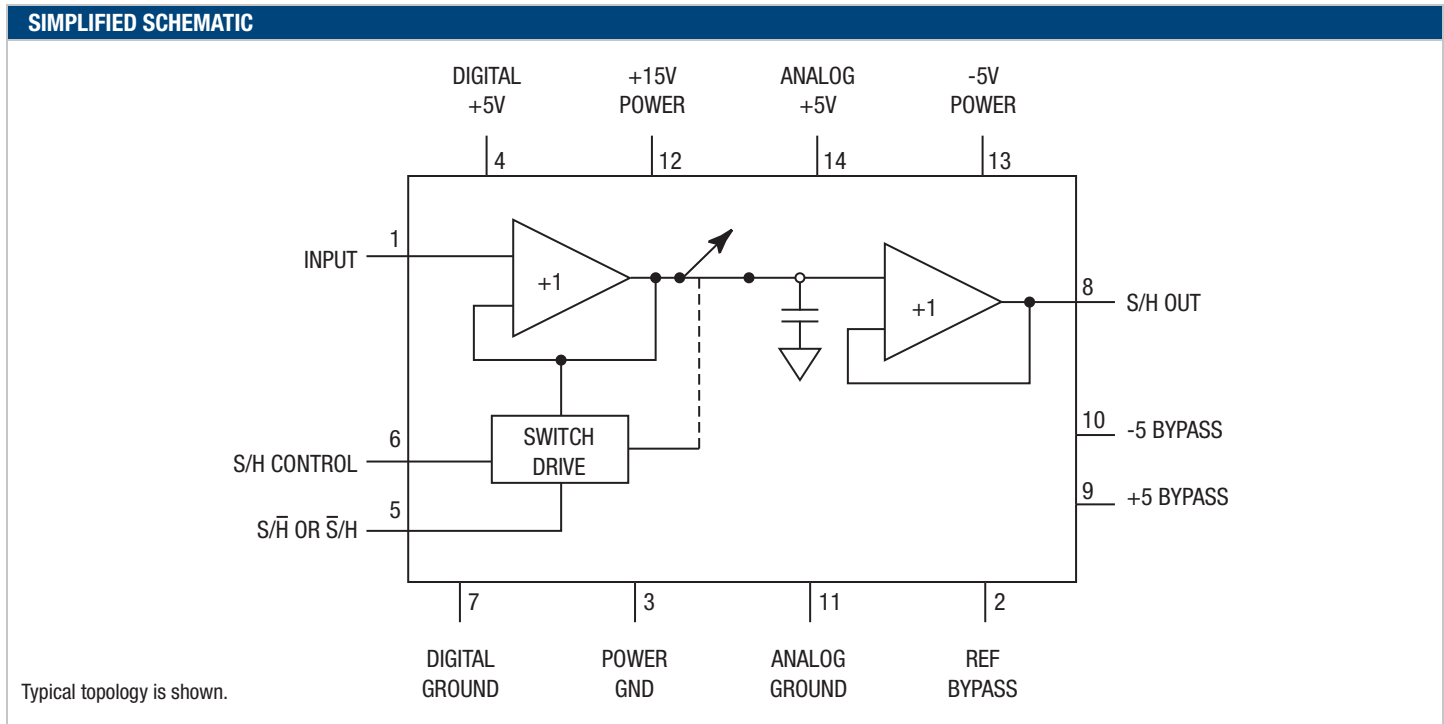

Figure 1. Simplified Block Diagram



Functional Specifications

Apply over the operating temperature range, ±1 Volt input range, 100Ω load, +15V, ±5V nominal supplies, unless otherwise specified.

PARAMETERS	MIN	TYP	MAX	UNITS
Input Voltage Range	-2	—	+2	Volts
Input Impedance	50	160	—	Kohms
Digital Inputs (Digital Supply = +5V)				
Logic Levels				
Logic 1	3.8	—	—	Vdc
Logic 0	—	—	1.35	Vdc
Logic Loading				
Logic 1	—	1	5	μA
Logic 0	—	1	5	μA
OUTPUTS				
Voltage Range	±2	—	—	V
Output Current	50	—	—	mA
Output Impedance (DC)	—	0.1	0.25	Ohms
Stable Capacitive Load	50	—	—	pF
PERFORMANCE				
Nonlinearity, DC (±1V)				
+25 °C	—	—	0.01	%
0 to +70 °C	—	—	0.01	%
-55 to +125 °C	—	—	0.02	%
Sample Mode Offset, +25 °C				
0 to +70 °C	—	±5	±30	mV
-55 to +125 °C	—	±25	±35	mV
Pedestal, 25 °C				
0 to +70 °C	—	±5	±15	mV
-55 to +125 °C	—	—	±20	mV
Gain, +25 °C				
—	—	1	—	V/V
Gain Error, +25 °C				
0 to +70 °C	—	—	±2	%
-55 to +125 °C	—	—	±2.25	%
Aperture Delay, +25 °C				
0 to +70 °C	—	5	10	nSec.
-55 to +125 °C	—	10	20	nSec.
Aperture Jitter, +25 °C				
0 to +70 °C	—	1	3	pS
-55 to +125 °C	—	2	6	pS
Slew Rate				
Full Power BW, ±1.5V	—	190	250	V/μSec.
Small Signal Bandwidth	20	25	—	MHz
Harmonic Distortion				
±1V, DC to 5 MHz	—	—	—	dB
±1V, 5 to 10 MHz, +25 °C	-70	-74	—	dB
0 to +70 °C	-60	-70	—	dB
-55 to +125 °C	-50	—	—	dB
Acq Time 0.01%, ±1V, +25 °C ①				
0 to +70 °C	—	25	35	nSec.
-55 to +125 °C	—	—	35	nSec.
Acq Time 0.1%, ±1V, +25 °C ①				
0 to +70 °C	—	15	25	nSec.
-55 to +125 °C	—	—	35	nSec.
Hold Mode Settling, 0.01%, +25 °C				
0 to +70 °C	—	20	30	nSec.
-55 to +125 °C	—	—	50	nSec.

PERFORMANCE, CONT.	MIN	TYP	MAX	UNITS
Hold Mode Settling,				
0.1%, +25 °C	—	—	30	nSec.
0 to +70 °C	—	—	35	nSec.
-55 to +125 °C	—	—	35	nSec.
Output Noise, Hold Mode	—	50	100	μV rms
Feedthrough Rejection 2V Step	-76	-80	—	dB
Droop Rate, +25 °C				
0 to +70 °C	—	1	5	μV/μS
-55 to +125 °C	—	25	50	μV/μS

POWER SUPPLY REQUIREMENTS

Range	MIN	TYP	MAX	UNITS
Analog +5V				
+4.75	+5.0	+5.25	Vdc	
Digital +5V				
+4.75	+5.0	+5.25	Vdc	
-5V				
-4.75	-5.0	-5.25	Vdc	
+15V				
+14.25	+15.0	+15.75	Vdc	
Current Usage				
Analog +5V				
—	+38	+45	mA	
Digital +5V				
—	+1.0	+50	mA	
-5V				
—	-47	-50	mA	
+15V				
—	8	12	mA	
Power Dissipation	—	545	655	mW
Power Supply Rejection Ratio	-52	-60	—	dB

ENVIRONMENTAL

Operating Temp. Range				
-MC, ambient	0	—	+70	°C
-MM, case	-55	—	+125	°C
Storage Temp. Range				
-65	—	+150	°C	
Package Type	14-Pin metal DIP			

① Murata Power Solutions (DATEL) uses the conservative definition of Acquisition time, which includes the Aperture Delay time.

Absolute Maximum Ratings

PARAMETERS	LIMITS	UNITS
+15V supply (pin 12)	-0.5 to +18	Vdc
+5V supply (pin 4, 14)	-0.5 to +7	Vdc
-5V supply (pin 13)	+0.5 to -7	Vdc
Analog input (pin 1)		
+5V Supply +1		Vdc
-5V Supply -1		Vdc
Digital inputs (pins 5, 6)		
-0.5 to +7		Vdc
Lead temperature (10 sec.)	300	°C
Short circuit to ground	70	mA
Output shorted to any supply will cause permanent damage.		

TECHNICAL NOTES

- Bypass the ±5V analog, +5V digital, +15V supplies with a 1μF, 25V tantalum capacitor in parallel with a 0.01 μF ceramic capacitor mounted as close to the pin as possible.
To achieve optimum performance-
- Additional bypass capacitors are necessary, because of internal high switching speeds, and high slew rates of internal components. REF BYPASS (pin 2), +5 BYPASS (pin 9), and -5 BYPASS (pin 10) are internal connections that must be bypassed with a minimum 1μF tantalum capacitor mounted as close to the pin as possible. The polarity of the connections are shown on the test circuit drawing, Figure 2.
- As with all high speed analog circuits, it is essential that good grounding techniques be used. Tie all ground pins together at a single ground point beneath the device, and use a short low impedance run to the ground of the analog power supplies. The ground point should be a solid ground plane under the device and any associated data converter.
- The offset, pedestal, and gain errors of the SHM-43 are laser trimmed at Murata Power Solutions (DATEL) and no external compensation capabilities have been provided. This prevents introducing noise through the offset adjust terminals of the S/H amplifier and guarantees excellent gain linearity, offset drift, and pedestal performance.

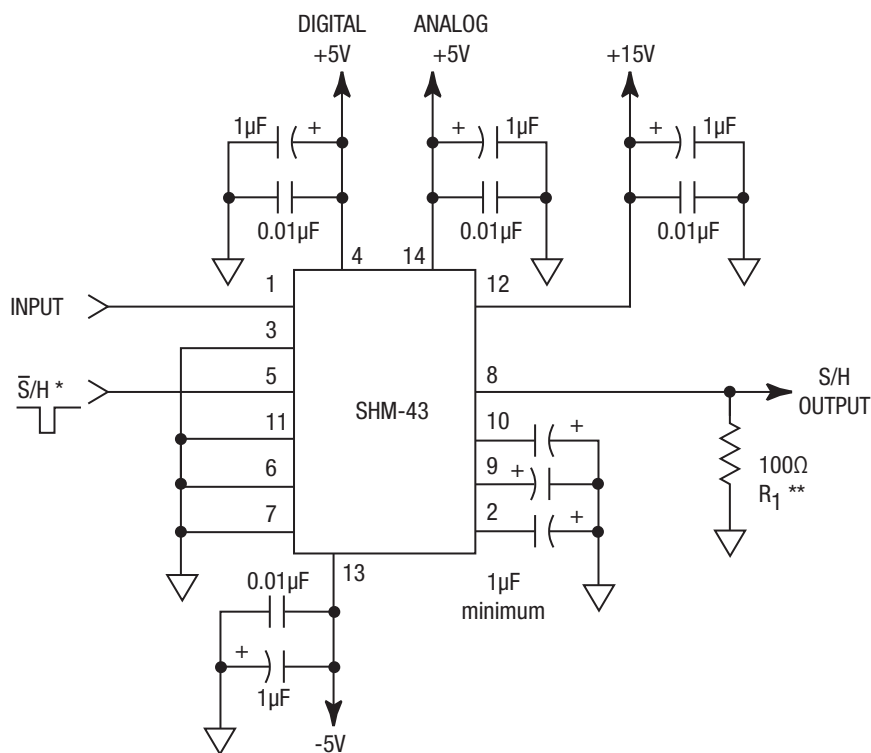

Figure 2. Test Circuit Connections

* Connections shown for $\overline{S/H}$; if opposite polarity sample hold command is desired, connect S/H CONTROL (pin 6) to DIGITAL +5V (pin 4). Using the opposite polarity S/H command will not effect speed or accuracy.

** The SHM-43 MS been optimized for driving 100Ω loads. R1 should be chosen so that the total load on the S/H is 100Ω.

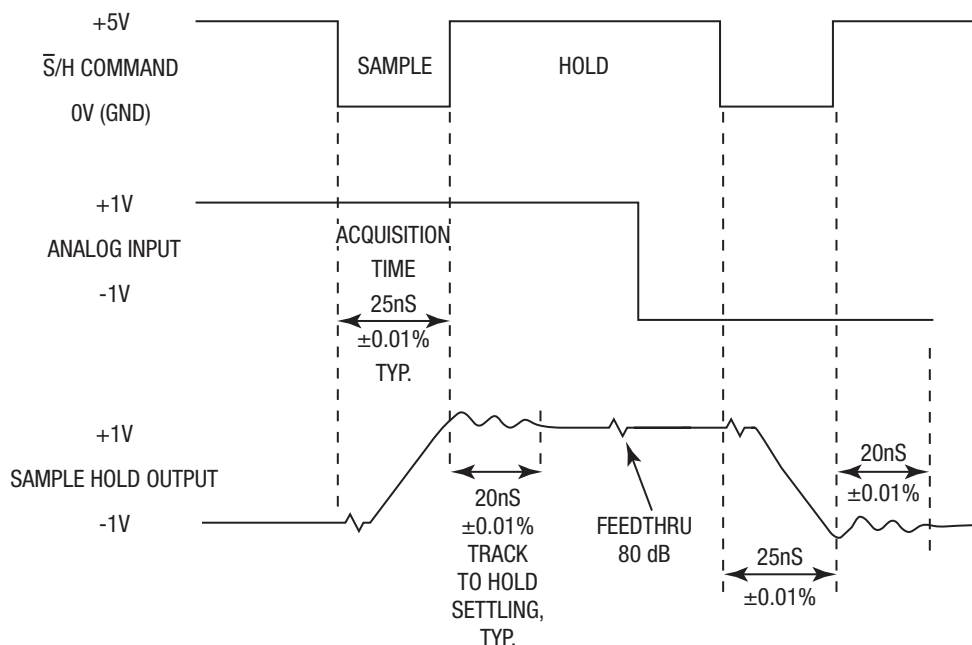

Figure 3. Test Method for Circuit Shown In Figure 2

