

### FEATURES

- 14-bit resolution
- 12.8MHz minimum sampling rate
- No missing codes over full military temperature range
- Ideal for both time and frequency-domain applications
- Excellent THD (-81dB) and SNR (78dB)
- Edge-triggered
- Small, 32-pin, side-brazed, ceramic TDIP or SMT
- Low-power, 2 Watts
- Low cost



### GENERAL DESCRIPTION

The low-cost ADS-949 is a 14-bit, 12.8MHz sampling A/D converter. This device accurately samples full-scale input signals up to Nyquist frequencies with no missing codes. Excellent differential nonlinearity error (DNL), signal-to-noise ratio (SNR), and total harmonic distortion (THD) make the ADS-949 the ideal choice for both time-domain (CCD/FPA imaging, scanners, process control) and frequency-domain (radar, telecommunications, spectrum analysis) applications.

The functionally complete ADS-949 contains a fast-settling sample/hold amplifier, a subranging A/D converter, an internal reference, timing/control logic, and error-correction circuitry. Digital input and output levels are TTL. The ADS-949 only requires the rising edge of a start convert pulse to operate.

Requiring only +15V, +5V and -5V supplies, the ADS-949 typically dissipates just 2 Watts. The device is offered with a Bipolar input range of  $\pm 2.5V$  and Unipolar range of 0 to 5 volts. Models are available for use in either commercial (0 to +70°C) or military (-55 to +125°C) operating temperature ranges.

### INPUT/OUTPUT CONNECTIONS

PIN	FUNCTION	PIN	FUNCTION
1	VIN A	32	RANGE
2	VIN B	31	GAIN ADJUST
3	-5V	30	+5V ANALOG
4	OFFSET ADJ.	29	ANALOG GND
5	RANGE REF.	28	+15V
6	2.5V REF.	27	+5V DIGITAL
7	START CONVERT	26	DIGITAL GND
8	EOC	25	OVERFLOW
9	ENABLE	24	MSB
10	BIT 14 (LSB)	23	BIT 1 (MSB)
11	BIT 13	22	BIT 2
12	BIT 12	21	BIT 3
13	BIT 11	20	BIT 4
14	BIT 10	19	BIT 5
15	BIT 9	18	BIT 6
16	BIT 8	17	BIT 7

A proprietary, auto-calibrating, error-correcting circuit allows the device to achieve specified performance over the full military temperature range.

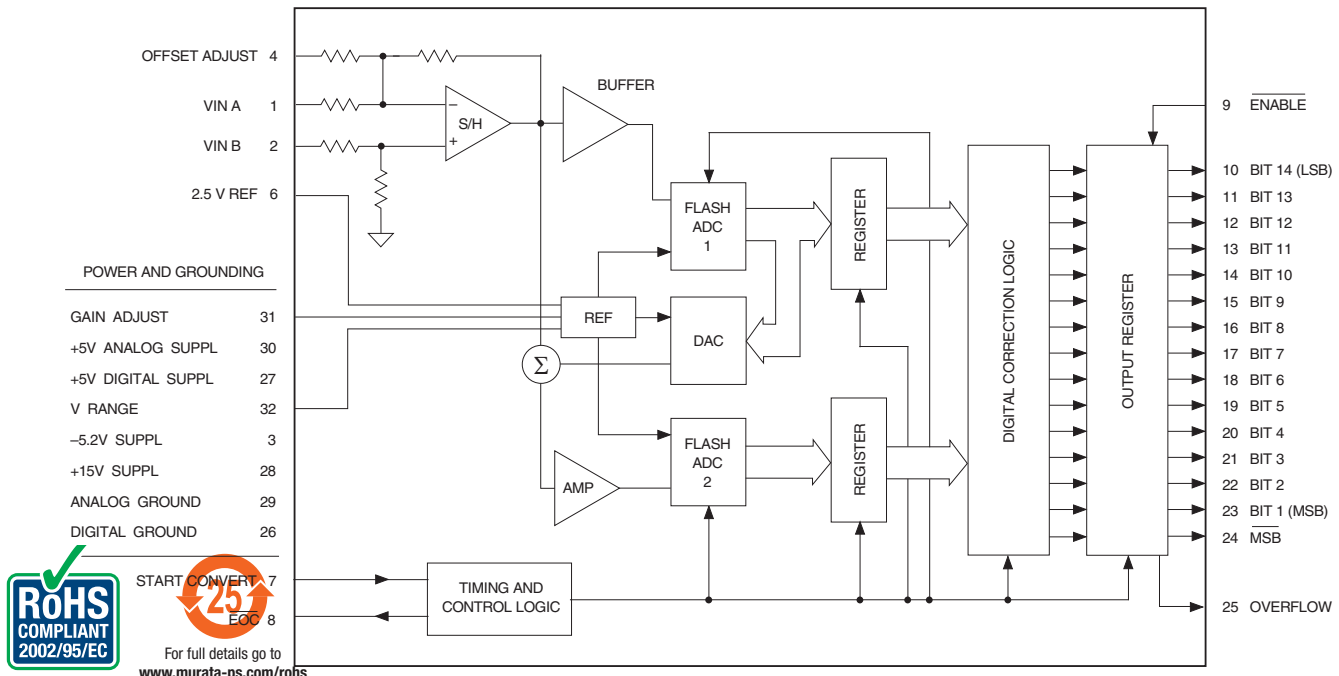


Figure 1. ADS-949 Functional Block Diagram



For full details go to [www.murata-ps.com/rohs](http://www.murata-ps.com/rohs)

### PHYSICAL/ENVIRONMENTAL

PARAMETERS	MIN.	TYP.	MAX.	UNITS
Operating Temp. Range, Case				
ADS-949MC, GC	0	—	+70	°C
ADS-949MM, GM,	-55	—	+125	°C
Thermal Impedance				
$\theta_{jc}$	—	6	—	°C/Watt
$\theta_{ca}$	—	23	—	°C/Watt
Storage Temperature Range	-65	—	+150	°C
Package Type	32-pin, side-brazed, ceramic TDIP or SMT			
Weight	0.46 ounces (13 grams)			

### ABSOLUTE MAXIMUM RATINGS

PARAMETERS	LIMITS	UNITS
+5V Supply (Pins 27, 30)	0 to +6	Volts
+15V Supply (Pin 28)	0 to +16	Volts
-5V Supply (Pin 3)	0 to -5.5V	Volts
Digital Input (Pin 7)	-0.3 to +V <sub>DD</sub> +0.3	Volts
Analog Input (Pins 1, 2)	±5	Volts
Lead Temperature (10 seconds)	+300	°C

### FUNCTIONAL SPECIFICATIONS

(T<sub>A</sub> = +25°C, +V<sub>DD</sub> = +5V, -V<sub>DD</sub> = -5V, +V<sub>CC</sub> = +15V, 12.8MHz sampling rate, ±2.5V input range, and a minimum 3 minute warmup ① unless otherwise specified.)

ANALOG INPUT	+25°C			0 to +70°C			-55 to +125°C			UNITS
	MIN.	TYP.	MAX.	MIN.	TYP.	MAX.	MIN.	TYP.	MAX.	
Bipolar Input Voltage Range ②	±1	—	±2.5	±1	—	±2.5	±1	—	±2.5	Volts
Unipolar Input Voltage Range ②	0 to 2	—	0 to 5	0 to 2	—	0 to 5	0 to 2	—	0 to 5	Volts
Input Resistance (Vin A)	—	400	—	—	400	—	—	400	—	Ω
Input Capacitance	—	6	15	—	6	15	—	6	15	pF
<b>DIGITAL INPUT</b>										
Logic Levels										
Logic "1"	+2.0	—	—	+2.0	—	—	+2.0	—	—	Volts
Logic "0"	—	—	+0.8	—	—	+0.8	—	—	+0.8	Volts
Logic Loading "1"	—	—	+20	—	—	+20	—	—	+20	μA
Logic Loading "0"	—	—	-20	—	—	-20	—	—	-20	μA
Start Convert Positive Pulse Width ③	—	50	—	—	50	—	—	50	—	ns
<b>STATIC PERFORMANCE</b>										
Resolution	—	14	—	—	14	—	—	14	—	Bits
Integral Nonlinearity	—	±0.75	—	—	±0.75	—	—	±1	—	LSB
Differential Nonlinearity (f <sub>in</sub> = 10kHz)	-0.95	±0.5	+1.25	-0.95	±0.5	+1.25	-0.95	±0.5	+1.5	LSB
Full Scale Absolute Accuracy	—	±0.15	±0.4	—	±0.15	±0.4	—	±0.4	±0.8	%FSR
Bipolar Zero Error (Tech Note 2)	—	±0.1	±0.3	—	±0.1	±0.3	—	±0.3	±0.6	%FSR
Gain Error (Tech Note 2)	—	±0.2	±0.4	—	±0.2	±0.4	—	±0.4	±1.5	%
No Missing Codes (f <sub>in</sub> = 10kHz)	14	—	—	14	—	—	14	—	—	Bits
<b>DYNAMIC PERFORMANCE</b>										
Peak Harmonics (-0.5dB)										
dc to 1MHz	—	-83	-76	—	-83	-75	—	-79	-71	dB
1MHz to 2.5MHz	—	-78	-72	—	-78	-72	—	-73	-68	dB
2.5MHz to 5MHz	—	-76	-71	—	-76	-71	—	-71	-65	dB
Total Harmonic Distortion (-0.5dB)										
dc to 1MHz	—	-81	-74	—	-81	-74	—	-77	-70	dB
1MHz to 2.5MHz	—	-76	-71	—	-76	-71	—	-72	-66	dB
2.5MHz to 5MHz	—	-74	-69	—	-74	-69	—	-69	-63	dB
Signal-to-Noise Ratio										
(w/o distortion, -0.5dB)										
dc to 1MHz	72	78	—	72	78	—	70	78	—	dB
1MHz to 2.5MHz	72	77	—	72	77	—	70	77	—	dB
2.5MHz to 5MHz	72	76	—	72	76	—	70	76	—	dB
Signal-to-Noise Ratio ④										
(& distortion, -0.5dB)										
dc to 1MHz	70	77	—	70	74	—	68	73	—	dB
1MHz to 2.5MHz	70	74	—	70	74	—	66	71	—	dB
2.5MHz to 5MHz	69	73	—	69	73	—	65	70	—	dB
Noise	—	150	—	—	150	—	—	150	—	μVrms
Two-tone Intermodulation										
Distortion (f <sub>in</sub> = 2.45MHz, 1.975MHz, f <sub>s</sub> = 10MHz, -0.5dB)	—	-82	—	—	-82	—	—	-82	—	dB
Input Bandwidth (-3dB)										
Small Signal (-20dB input)	—	30	—	—	30	—	—	30	—	MHz
Large Signal (-0.5dB input)	—	20	—	—	20	—	—	20	—	MHz
Feedthrough Rejection (f <sub>in</sub> = 5MHz)	—	85	—	—	85	—	—	85	—	dB
Slew Rate	—	±400	—	—	±400	—	—	±400	—	V/μs
Aperture Delay Time	—	+5	—	—	+5	—	—	+5	—	ns
Aperture Uncertainty	—	2	—	—	2	—	—	2	—	ps rms

DYNAMIC PERFORMANCE (Cont.)	+25°C			0 to +70°C			-55 to +125°C			UNITS
	MIN.	TYP.	MAX.	MIN.	TYP.	MAX.	MIN.	TYP.	MAX.	
S/H Acquisition Time (to ±0.003%FSR, 5V step)	—	40	45	—	40	45	—	40	45	ns
Overvoltage Recovery Time	—	—	100	—	—	100	—	—	100	ns
A/D Conversion Rate	12.8	—	—	12.8	—	—	12.8	—	—	MHz
<b>DIGITAL OUTPUTS</b>										
Logic Levels										
Logic "1"	+2.4	—	—	+2.4	—	—	+2.4	—	—	Volts
Logic "0"	—	—	+0.4	—	—	+0.4	—	—	+0.4	Volts
Logic Loading "1"	—	—	-4	—	—	-4	—	—	-4	mA
Logic Loading "0"	—	—	+4	—	—	+4	—	—	+4	mA
Output Coding	Straight Binary, Offset Binary									
<b>DIGITAL OUTPUTS</b>										
Power Supply Ranges										
+5V Supply	+4.75	+5.0	+5.25	+4.75	+5.0	+5.25	+4.9	+5.0	+5.25	Volts
-5.2V Supply	-4.75	-5.2	-5.45	-4.75	-5.2	-5.45	-4.9	-5.2	-5.45	Volts
+15V Supply	+14.5	+15	+15.5	+14.5	+15	+15.5	+14.5	+15	+15.5	Volts
Power Supply Currents										
+5V Supply	—	+250	+260	—	+250	+260	—	+250	+260	mA
-5.2V Supply	—	-200	-210	—	-200	-210	—	-200	-210	mA
+15V Supply	+14.5	+15	+15.5	+14.5	+15	+15.5	+14.5	+15	+15.5	Volts
Power Dissipation	—	2.0	2.25	—	2.0	2.25	—	2.0	2.25	Watts
Power Supply Rejection	—	—	±0.1	—	—	±0.1	—	—	±0.1	%FSR/%V
<b>Footnotes:</b>										
① All power supplies should be on before applying a start convert pulse. All supplies and the clock (start convert pulses) must be present during warmup periods. The device must be continuously converting during this time.						④ Effective bits is equal to: $\frac{(\text{SNR} + \text{Distortion}) - 1.76}{6.02} + \left[ 20 \log \frac{\text{Full Scale Amplitude}}{\text{Actual Input Amplitude}} \right]$				
② Contact Murata Power Solutions for other input voltage ranges.										
③ A 50ns wide start convert pulse is used for all production testing. For applications requiring less than an 12.8MHz sampling rate, wider start convert pulses can be used. The rising edge of the start convert pulse needs to be as sharp as possible (<10 ns). Otherwise, a degradation in performance can result from a slow rising edge pulse.										

**TECHNICAL NOTES**

- Obtaining fully specified performance from the ADS-949 requires careful attention to pc card layout and power supply decoupling. The device's analog and digital ground systems are connected to each other internally. For optimal performance, tie all ground pins (26 and 29) directly to a large **analog** ground plane beneath the package.  
  
Bypass all power supplies to ground with 4.7µF tantalum capacitors in parallel with 0.1µF ceramic capacitors. Locate the bypass capacitors as close to the unit as possible.
- The ADS-949 achieves its specified accuracies without the need for external calibration. It is recommended that the +5VA and +5VD supplies should be powered up from

the same source. If required, the device's small initial offset and gain errors can be reduced to zero using the adjustment circuitry shown in Figure 2, 3.

When using this circuitry, or any similar offset and gain calibration hardware, make adjustments following warmup. To avoid interaction, always adjust offset before gain.

- Applying a start convert pulse while a conversion is in progress (EOC = logic 1) will initiate a new and inaccurate conversion cycle. Data for the interrupted and subsequent conversions will be invalid.
- A passive bandpass filter is used at the input of the A/D for all production testing.

**CALIBRATION PROCEDURE**

Any offset and/or gain calibration procedures should not be implemented until devices are fully warmed up. To avoid interaction, offset must be adjusted before gain. The ranges of adjustment for the circuits in Figures 2 and 3 are guaranteed to compensate for the ADS-949's initial accuracy errors and may not be able to compensate for additional system errors.

A/D converters are calibrated by positioning their digital outputs exactly on the transition point between two adjacent digital output codes. This can be accomplished by connecting LED's to the digital outputs and adjusting until certain LED's "flicker" equally between on and off. Other approaches employ digital comparators or microcontrollers to detect when the outputs change from one code to the next.

Offset adjusting for the ADS-949 is normally accomplished at the point where the MSB is a 1 and all other output bits are 0's and the LSB just changes from a 0 to a 1. This digital output transition ideally occurs when the applied analog input is  $+\frac{1}{2}$  LSB ( $+153\mu\text{V}$ ).

Gain adjusting is accomplished when all bits are 1's and the LSB just changes from a 1 to a 0. This transition ideally occurs when the analog input is at +full scale minus  $\frac{1}{2}$  LSB's ( $+2.49954\text{V}$ ).

**Zero/Offset Adjust Procedure**

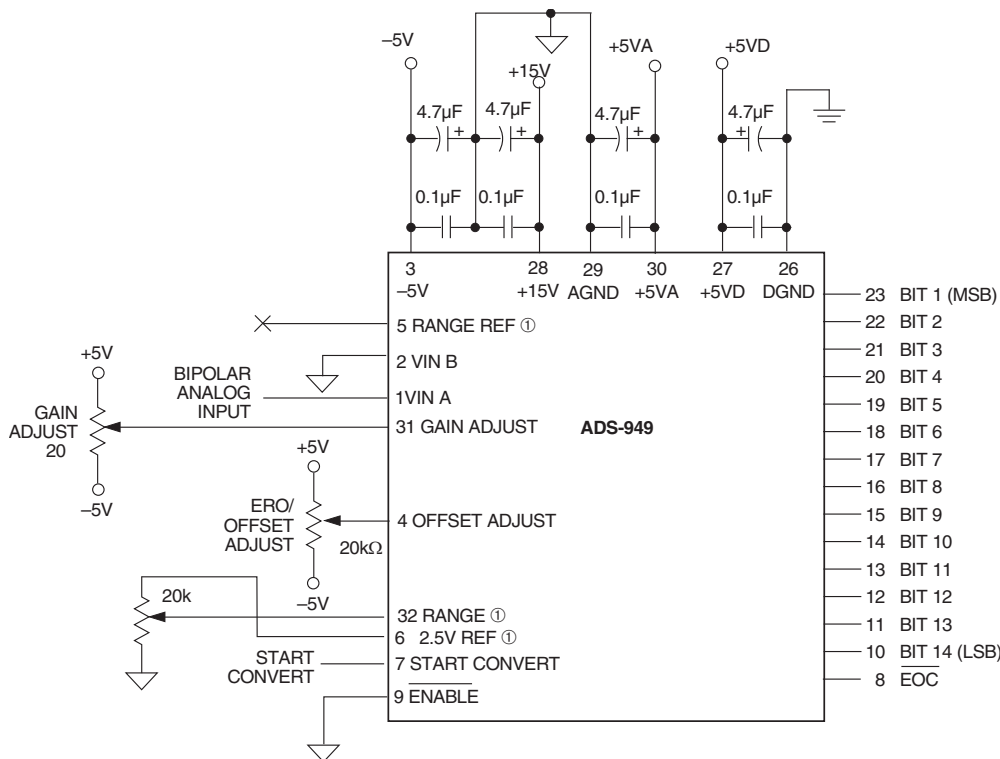
1. Apply a train of pulses to the START CONVERT input (pin 7) so the converter is continuously converting.
2. Apply  $+153\mu\text{V}$  to the ANALOG INPUT (pin 1).
3. Adjust the offset potentiometer until the output bits are 10 0000 0000 0000 and the LSB flickers between 0 and 1.

**Gain Adjust Procedure**

1. Apply  $+2.49954\text{V}$  to the ANALOG INPUT (pin 1).
2. Adjust the gain potentiometer until all output bits are 1's and the LSB flickers between 1 and 0.
3. To confirm proper operation of the device, vary the input signal to obtain the output coding listed in Table 2.

**Table 1. Gain and Zero Adjust**

INPUT VOLTAGE RANGE	ZERO ADJUST $+\frac{1}{2}$ LSB	GAIN ADJUST $+FS -\frac{1}{2}$ LSB
$\pm 2.5\text{V}$	$+153\mu\text{V}$	$+2.49954\text{V}$



① Bypass Pins 5, 6, 32, with a 4.7μF to Analog Ground.

Note The Voltage Value at Pin 32 (Range) sets the input voltage range of the ADS-949

eg If Pin 6 (2.5V Reference Out) is tied to the Range Pin 32 (20k Pot is shorted), then the input range of the ADS-949 becomes  $\pm 2.5\text{V}$

If the 20k Pot is set at midrange then the input range of the ADS-949 becomes  $\pm 1.25\text{V}$

**Figure 2. Typical ADS-949 Bipolar Connection Diagram**

**THERMAL REQUIREMENTS**

All MPS sampling A/D converters are fully characterized and specified over operating temperature (case) ranges of 0 to +70°C and -55 to +125°C. All room temperature (T<sub>A</sub> = +25°C) production testing is performed without the use of heat sinks or forced air cooling. Thermal impedance figures for each device are listed in their respective specification tables.

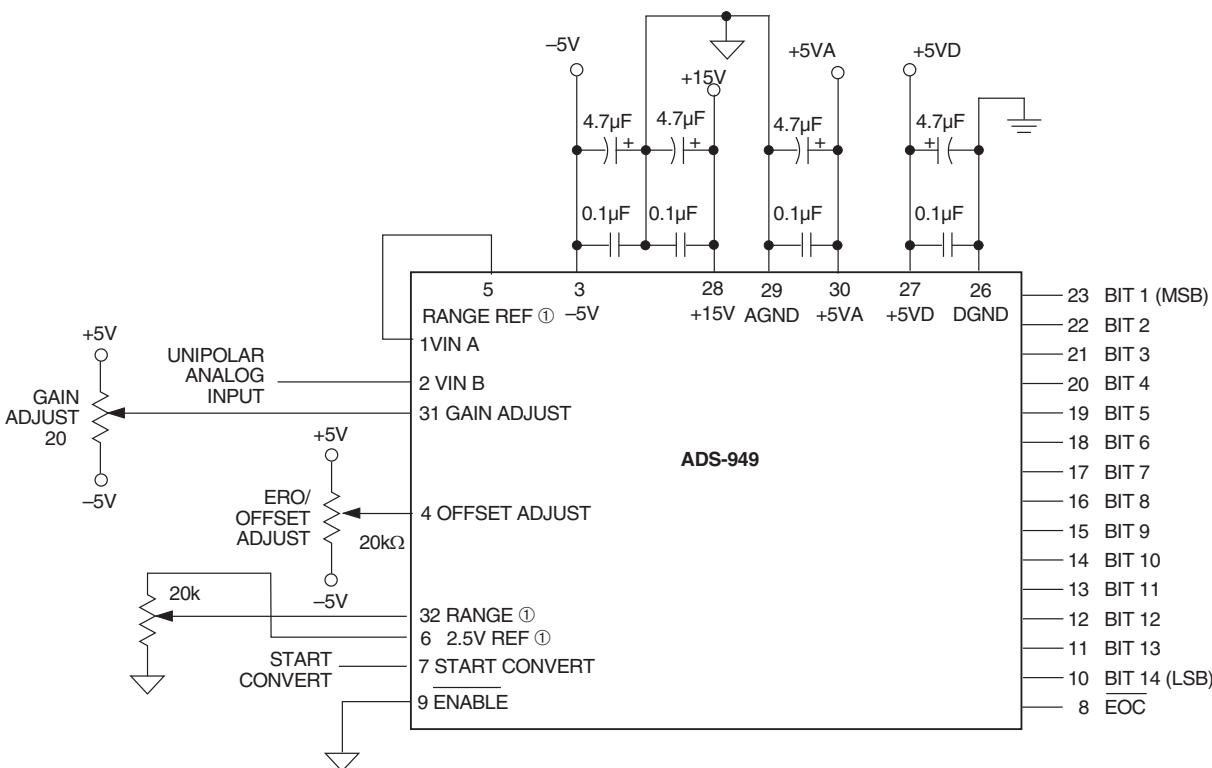
These devices do not normally require heat sinks, however, standard precautionary design and layout procedures should be used to ensure devices do not overheat. The ground and power planes beneath the package, as well as all pcb signal runs to and from the device, should be as heavy as possible to help conduct heat away from the package.

Electrically-insulating, thermally-conductive "pads" may be installed underneath the package. Devices should be soldered to boards rather than socketed, and of course, minimal air flow over the surface can greatly help reduce the package temperature.

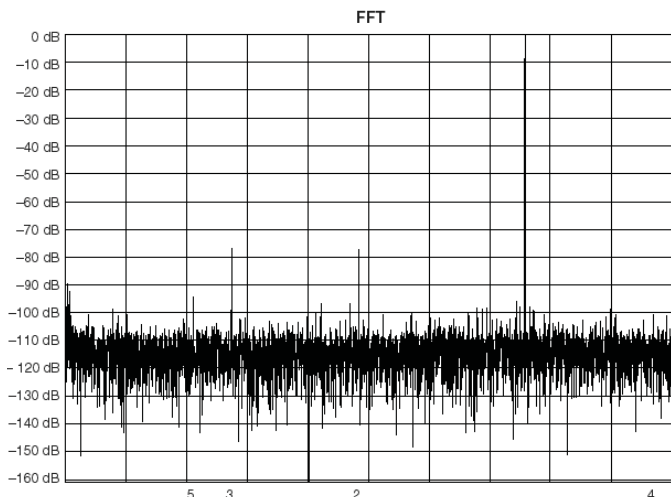
In more severe ambient conditions, the package/junction temperature of a given device can be reduced dramatically (typically 35%) by using one of MPS's HS Series heat sinks. See Ordering Information for the assigned part number. See page 1-183 of the MPS Data Acquisition Components Catalog for more information on the HS Series. Request MPS Application Note AN8, "Heat Sinks for DIP Data Converters", or contact Murata Power Solutions directly, for additional information.

**Table 3. Output Coding**

STRAIGHT BIN.									
UNIPOLAR SCALE	INPUT VOLT. 0 TO +5V	MSB		LSB		OUTPUT CODING MSB	OUTPUT CODING LSB	INPUT VOLT. ±2.5V	BIPOLAR SCALE
		MSB	LSB	MSB	LSB				
+FS - 1 LSB	+4.999695	11	1111 1111 1111	01	1111 1111 1111	01	1111 1111 1111	+2.499695	+FS - 1LSB
+7/8 FS	+4.375000	11	1000 0000 0000	01	1000 0000 0000	01	1000 0000 0000	+1.875000	+3/4FS
+3/4 FS	+3.750000	11	0000 0000 0000	01	0000 0000 0000	01	0000 0000 0000	+1.250000	+1/2FS
+1/2 FS	+2.500000	10	0000 0000 0000	00	0000 0000 0000	00	0000 0000 0000	0.000000	0
+1/4 FS	+1.250000	01	0000 0000 0000	11	0000 0000 0000	11	0000 0000 0000	-1.250000	-1/2FS
+1/8 FS	+0.625000	00	1000 0000 0000	10	1000 0000 0000	10	1000 0000 0000	-1.875000	-3/4FS
+1 LSB	+0.000305	00	0000 0000 0001	10	0000 0000 0001	10	0000 0000 0001	-2.499695	-FS+1LSB
0	0.000000	00	0000 0000 0000	10	0000 0000 0000	10	0000 0000 0000	-2.500000	-FS
				OFF. BINARY		TWO'S COMP.			

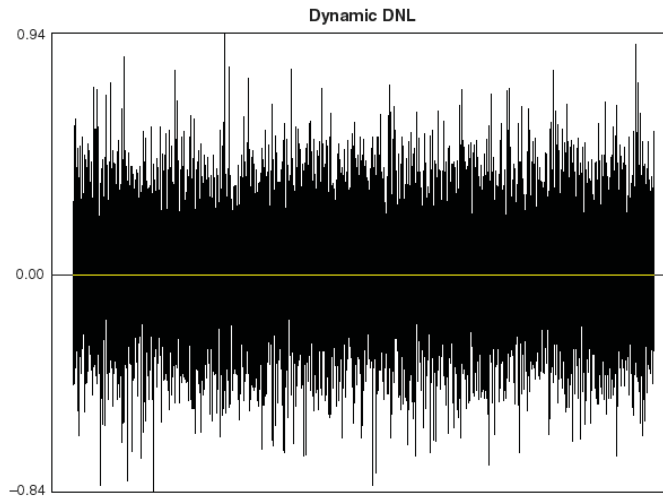


**Figure 3. Typical ADS-949 Unipolar Connection Diagram**

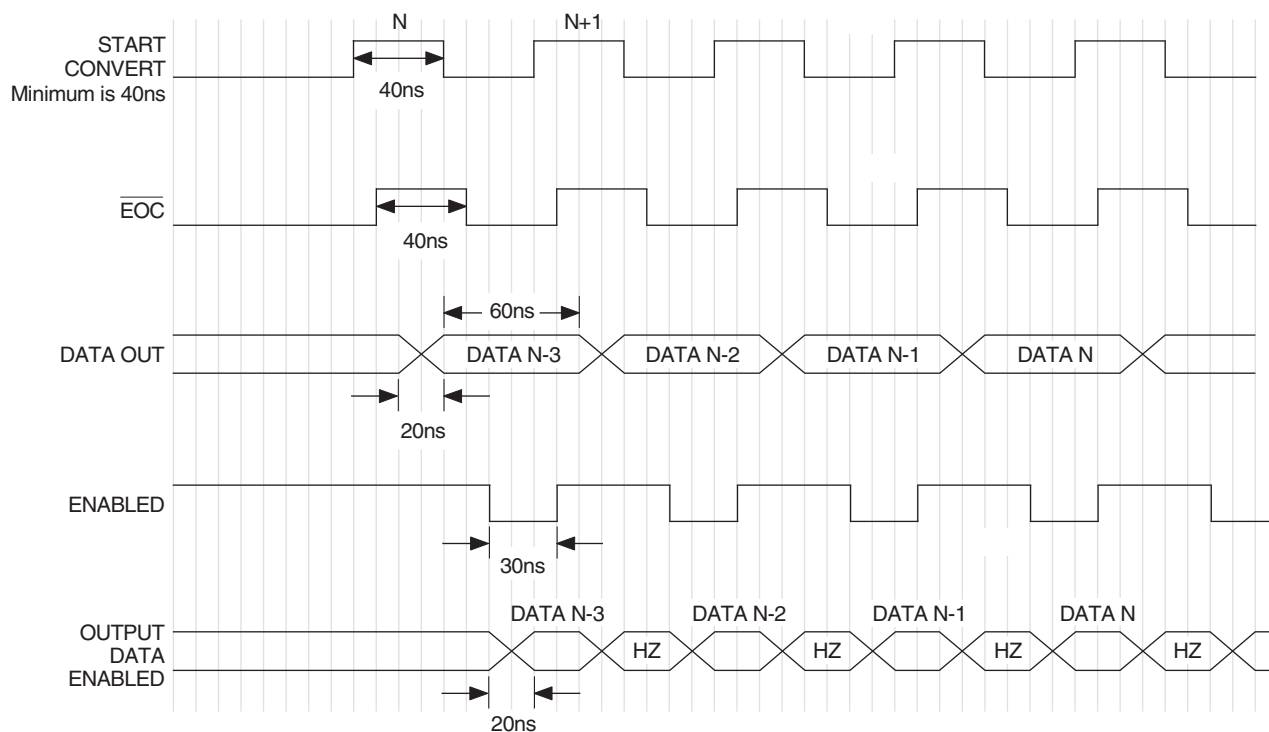


**Figure 4. FFT Analysis of ADS-949**

(fs = 12.8MHz, fin = 3.85MHz, Vin = -0.5dB, 16,384 point FFT)



**Figure 5. ADS-949 Histogram**



Notes: 1. Scale is approximately 10ns per division. All values are Typical.  
 2. Rising edge of the start convert needs to be less than 10 ns.

**Figure 6. ADS-949 Timing Diagram**

CONTACT MURATA POWER SOLUTIONS FOR SCHEMATIC

Figure 7. ADS-949 Evaluation Board Schematic (ADS-B949)

