

FEATURES

- 14-bit resolution
- 10MHz minimum throughput
- Functionally complete
- No missing codes
- Low power, 4.0W
- Excellent dynamic performance
- Internally clamped input
- Edge triggered
- TTL compatible
- 2" x 4" module
- Very low profile



GENERAL DESCRIPTION

The low-cost ADS-945 is a high-performance, 14-bit, 10MHz sampling A/D converter. This device accurately samples full-scale input signals up to Nyquist frequencies with no missing codes. The dynamic performance of the ADS-945 has been optimized to achieve a THD of -80dB and a SNR of 75dB.

Packaged in a 2" x 4" module, the functionally complete ADS-945 contains a fast-settling sample/hold amplifier, a subranging (two-pass) A/D converter, a precise voltage reference, timing/control logic, three-state outputs, and error-correction circuitry. Digital inputs and outputs are TTL compatible (except for pins 29 and 30 which are ECL).

Requiring ±15V, +5V and -5.2V supplies, the ADS-945 typically dissipates 4.0W. The unit is offered with a bipolar input range of ±1.25V. Models are available for use in either commercial (0 to +70°C) or military (-55 to +125°C) operating temperature ranges. Typical applications include radar signal analysis, medical/graphic imaging, and FFT spectrum analysis.

INPUT/OUTPUT CONNECTIONS

PIN	FUNCTION	PIN	FUNCTION
1	ANALOG GROUND	70-76	ANALOG GROUND
4	ANALOG INPUT	69	+5V ANALOG SUPPLY
5-6	ANALOG GROUND	64-68	ANALOG GROUND
7	+10V REFERENCE OUT	63	-5.2V ANALOG SUPPLY
8	ANALOG GROUND	62	ANALOG GROUND
9	GAIN ADJUST	61	NO CONNECT
10-11	DO NOT CONNECT	58-60	DIGITAL GROUND
12	-15V SUPPLY	57	-5.2V DIGITAL SUPPLY
13	ANALOG GROUND	56	DO NOT CONNECT
14	+15V SUPPLY	55	+5V DIGITAL SUPPLY
15-17	ANALOG GROUND	54	DIGITAL GROUND
18	OFFSET ADJUST	53	BIT 1 (MSB)
19-25	ANALOG GROUND	52	BIT 2
26	MISSING PIN	51	BIT 3
27	DIGITAL GROUND	50	BIT 4
28	DIGITAL GROUND	49	BIT 5
29	T/H STATUS	48	BIT 6
30	T/H STATUS	47	BIT 7
31	DIGITAL GROUND	46	BIT 8
32	START CONVERT	45	BIT 9
33	OVERFLOW	44	BIT 10
34	OUTPUT ENABLE (\overline{OE})	43	BIT 11
35	DIGITAL GROUND	42	BIT 12
36	NO CONNECT	41	BIT 13
37	DIGITAL GROUND	40	BIT 14 (LSB)
38	DIGITAL GROUND	39	DIGITAL GROUND

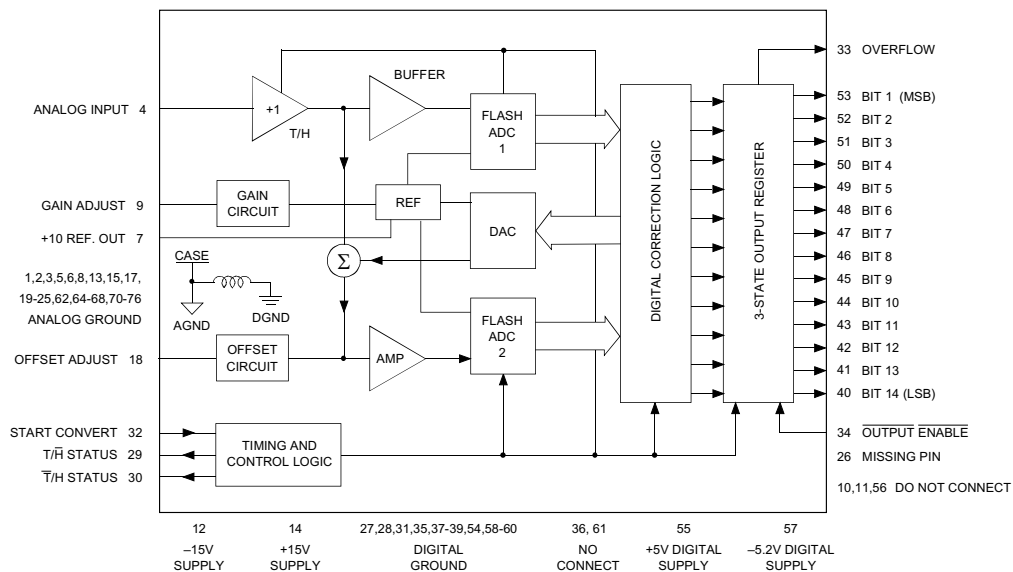

Figure 1. ADS-945 Functional Block Diagram

ABSOLUTE MAXIMUM

PARAMETERS	LIMITS	UNITS
+15V Supply (Pins 14)	0 to +16	Volts
-15V Supply (Pin 12)	0 to -16	Volts
+5V Supply (Pins 55, 69)	0 to +6	Volts
-5V Supply (Pin 57, 63)	0 to -6	Volts
Digital Input (Pin 32, 34)	-0.3 to +V _{DD} +0.3	Volts
Analog Input (Pin 4)	-15 to +15	Volts
Lead Temperature (10 seconds)	+300	°C

PHYSICAL/ENVIRONMENTAL

PARAMETERS	MIN.	TYP.	MAX.	UNITS
Operating Temp. Range, Case				
ADS-945	0	—	+70	°C
ADS-945EX	-55	—	+125	°C
Thermal Impedance				
θ_{jc}	—	10	—	°C/Watt
θ_{ca}	—	8	—	°C/Watt
Storage Temperature Range	-65	—	+150	°C
Package Type	2" x 4" module			
Weight	2.1 oz. (60 grams)			

FUNCTIONAL SPECIFICATIONS

(T_A = +25°C, ±V_{CC} = ±15V, +V_{DD} = +5V, V_{DD} = -5.2V, 10MHz sampling rate, and a minimum 10 minute warmup ① unless otherwise specified.)

ANALOG INPUT	+25°C			0 to + 0°C			55 to +125°C			UNITS
	MIN.	TYP.	MAX.	MIN.	TYP.	MAX.	MIN.	TYP.	MAX.	
Input Voltage Range ②	—	±1.25	—	—	±1.25	—	—	±1.25	—	Volts
Input Resistance	300	500	—	300	500	—	300	500	—	k Ω
Input Capacitance	—	10	15	—	10	15	—	10	15	pF
Input Bias Current	—	±3	—	—	±3	—	—	±3	—	μ A
DIGITAL INPUT										
Logic Levels										
Logic "1"	+2.0	—	—	+2.0	—	—	+2.0	—	—	Volts
Logic "0"	—	—	+0.8	—	—	+0.8	—	—	+0.8	Volts
Logic Loading "1"	—	—	+20	—	—	+20	—	—	+20	μ A
Logic Loading "0"	—	—	-20	—	—	-20	—	—	-20	μ A
Start Convert Positive Pulse Width ③	10	50	—	10	50	—	10	50	—	ns
STATIC PERFORMANCE										
Resolution	—	14	—	—	14	—	—	14	—	Bits
Integral Nonlinearity (dc input)	—	±0.5	—	—	±0.75	—	—	±1	—	LSB
Differential Nonlinearity (f _{in} = 10kHz)	-0.99	±0.5	+1.5	-0.99	±0.5	+1.5	-0.99	±0.75	+2.5	LSB
Full Scale Absolute Accuracy	—	±0.2	±0.4	—	±0.3	±0.5	—	±0.3	±0.7	%FSR
Bipolar Offset Error (Tech Note 2)	—	±0.15	±0.25	—	±0.25	±0.5	—	±0.3	±0.7	%FSR
Gain Error (Tech Note 2)	—	±0.1	±0.2	—	±0.2	±0.4	—	±0.3	±0.7	%
No Missing Codes (f _{in} = 10kHz)	14	—	—	14	—	—	14	—	—	Bits
DYNAMIC PERFORMANCE										
Peak Harmonics (-0.5dB)										
dc to 1mHz	—	-80	-75	—	—	—	—	—	—	dB
1MHz to 2.5MHz	—	-80	-75	—	—	—	—	—	—	dB
2.5MHz to 5MHz	—	-79	-73	—	-79	-73	—	-75	-69	dB
Total Harmonic Distortion (-0.5dB)										
dc to 1MHz	—	-80	-75	—	—	—	—	—	—	dB
1MHz to 2.5MHz	—	-80	-74	—	—	—	—	—	—	dB
2.5MHz to 5MHz	—	-78	-71	—	-78	-71	—	-75	-68	dB
Signal-to-Noise Ratio										
(w/o distortion, -0.5dB)										
dc to 1MHz	71	75	—	—	—	—	—	—	—	dB
100kHz to 2.5MHz	71	75	—	—	—	—	—	—	—	dB
2.5MHz to 5MHz	70	74	—	69	74	—	67	72	—	dB
(& distortion, -0.5dB)										
dc to 100kHz	70	77	—	—	—	—	—	—	—	dB
1MHz to 2.5MHz	70	74	—	—	—	—	—	—	—	dB
2.5MHz to 5MHz	69	73	—	69	73	—	65	70	—	dB
Noise	—	110	—	—	110	—	—	110	—	μ Vrms
Two-tone Intermodulation										
Distortion (f _{in} = 1.975MHz, 2.45MHz, f _s = 10MHz, -0.5dB)	—	-84	—	—	-84	—	—	-84	—	dB
Input Bandwidth (-3dB)										
Small Signal (-20dB input)	—	100	—	—	100	—	—	100	—	MHz
Large Signal (-0.5dB input)	—	50	—	—	50	—	—	50	—	MHz
Feedthrough Rejection (f _{in} = 4.85MHz)	—	90	—	—	90	—	—	90	—	dB
Slew Rate	—	±650	—	—	±650	—	—	±650	—	V/ μ s
Aperture Delay Time	—	±8	—	—	±8	—	—	±8	—	ns
Aperture Uncertainty	—	2	—	—	2	—	—	2	—	ps rms

DYNAMIC PERFORMANCE	+25°C			0 to + 0°C			55 to +125°C			UNITS
	MIN.	TYP.	MAX.	MIN.	TYP.	MAX.	MIN.	TYP.	MAX.	
S/H Acquisition Time (to ±0.003%FSR, 2.5V step)	—	40	—	—	40	—	—	40	—	ns
Overvoltage Recovery Time ⑤	—	30	100	—	30	100	—	30	100	ns
A/D Conversion Rate	10	—	—	10	—	—	10	—	—	MHz
ANALOG OUTPUT										
Reference Output	+9.95	+10	+10.05	+9.95	+10	+10.05	+9.95	+10	+10.05	Volts
Reference Temperature Drift	—	±40	—	—	±40	—	—	±40	—	ppm/°C
Reference Load Current	—	—	2.0	—	—	2.0	—	—	2.0	mA
DIGITAL OUTPUTS										
Logic Levels										
Logic "1"	+2.7	—	—	+2.7	—	—	+2.7	—	—	Volts
Logic "0"	—	—	+0.5	—	—	+0.5	—	—	+0.5	Volts
Logic Loading "1"	—	—	-0.4	—	—	-0.4	—	—	-0.4	mA
Logic Loading "0"	—	—	-8	—	—	-8	—	—	-8	mA
Delay, Rising Edge of Start Convert to Output Data Valid	—	—	35	—	—	35	—	—	35	ns
Delay, Edge of ENABLE to Output Data Valid/Invalid	—	—	18	—	—	18	—	—	18	ns
Output Coding	Complementary Offset Binary									
POWER REQUIREMENTS										
Power Supply Ranges										
+15V Supply	+14.25	+15.0	+15.75	+14.25	+15.0	+15.75	+14.25	+15.0	+15.75	Volts
-15V Supply	-14.25	-15.0	-15.75	-14.25	-15.0	-15.75	-14.25	-15.0	-15.75	Volts
+5V Supply	+4.75	+5.0	+5.25	+4.75	+5.0	+5.25	+4.75	+5.0	+5.25	Volts
-5.2V Supply	-4.95	-5.2	-5.45	-4.95	-5.2	-5.45	-4.95	-5.2	-5.45	Volts
Power Supply Currents ⑥										
+15V Supply	—	+35	+45	—	+35	+45	—	+35	+45	mA
-15V Supply	—	-10	-20	—	-10	-20	—	-10	-20	mA
+5V Supply	—	+290	+320	—	+290	+320	—	+290	+320	mA
-5.2V Supply	—	-350	-390	—	-350	-390	—	-350	-390	mA
Power Dissipation	—	4.0	4.3	—	4.0	4.3	—	4.0	4.3	Watts
Power Supply Rejection	—	—	±0.04	—	—	±0.04	—	—	±0.04	%FSR/%V
Footnotes:										
① All power supplies should be on before applying a start convert pulse. All supplies and the clock (start convert pulses) must be present during warmup periods. The device must be continuously converting during this time.					④ Effective bits is equal to: $\frac{(\text{SNR} + \text{Distortion}) - 1.76}{6.02} + \left[20 \log \frac{\text{Full Scale Amplitude}}{\text{Actual Input Amplitude}} \right]$					
② The input to the ADS-945 is internally clamped at ±2.3V.					⑤ This is the time required before the A/D output is valid after the analog input is back within its range.					
③ An 50ns wide start convert pulse is used for all production testing. For applications requiring less than a 10MHz sampling rate, a wider start convert can be used.					⑥ Typical +5V and -5.2V current drain breakdowns are as follows: +5V _{Analog} = +195mA -5.2V _{Analog} = -170mA +5V _{Digital} = + 95mA -5.2V _{Digital} = -180mA +5V _{Total} = +290mA -5.2V _{Total} = -350mA					

TECHNICAL NOTES

- Obtaining fully specified performance from the ADS-945 requires careful attention to pc-card layout and power supply decoupling. The device's analog and digital ground systems are connected to each other internally. For optimal performance, tie all ground pins directly to a large **analog** ground plane beneath the package.

Bypass all power supplies to ground with 10µF tantalum capacitors in parallel with 0.1µF ceramic capacitors. **The bypass capacitors should be located as close to the unit as possible.**
- The ADS-945 achieves its specified accuracies without the need for external calibration. If required, the device's small initial offset and gain errors can be reduced to zero using

the adjustment circuitry shown in Figure 2. The typical adjustment range is ±0.2%FSR for this circuitry.

When using this circuitry, or any similar offset and gain-calibration hardware, make adjustments following warmup. To avoid interaction, always adjust offset before gain.

- To enable the three-state outputs, apply a logic "0" (low) to OUTPUT ENABLE (pin 34). To disable, apply a logic "1" (high) to pin 34.
- A passive bandpass filter (Allen Avionics F4202 Series) is used at the input of the A/D for all production testing.
- The ADS-945's digital outputs should not be directly connected to a noisy data bus. Drive the bus with 573 or 574 type latches and use "low-noise" logic, such as the 74ALS series.

CALIBRATION PROCEDURE

(Refer to Figure 2 and Table 1)

Note: Connect pin 18 to ANALOG GROUND (pin 19) for operation without zero/offset adjustment. Connect pin 9 to ANALOG GROUND (pin 8) for operation without gain adjustment.

Any offset and/or gain calibration procedures should not be implemented until devices are fully warmed up. To avoid interaction, offset must be adjusted before gain. The ranges of adjustment for the circuit in Figure 2 are guaranteed to compensate for the ADS-945's initial accuracy errors and may not be able to compensate for additional system errors.

A/D converters are calibrated by positioning their digital outputs exactly on the transition point between two adjacent digital output codes. This can be accomplished by connecting LED's to the digital outputs and adjusting until certain LED's "flicker" equally between on and off. Other approaches employ digital comparators or microcontrollers to detect when the outputs change from one code to the next.

For the ADS-945, offset adjusting is normally accomplished at the point where the MSB is a 1 and all other output bits are 0's and the LSB just changes from a 0 to a 1. This digital output transition ideally occurs when the applied analog input is $\pm\frac{1}{2}$ LSB ($\pm 76.3\mu\text{V}$).

Gain adjusting is accomplished when all bits are 0's and the LSB just changes from a 0 to a 1. This transition ideally occurs when the analog input is at +full scale minus $1\frac{1}{2}$ LSB's ($+1.249771\text{V}$).

Note: Due to inherent system noise, the averaging of several conversions may be needed to accurately adjust both offset and gain to 1LSB of accuracy.

Zero/Offset Adjust Procedure

1. Apply a train of pulses to the START CONVERT input (pin 32) so the converter is continuously converting.
2. Apply $+76.3\mu\text{V}$ to the ANALOG INPUT (pin 4).
3. Adjust the offset potentiometer until the output bits are 10 0000 0000 0000 and the LSB flickers between 0 and 1.

Gain Adjust Procedure

1. Apply $+1.249771\text{V}$ to the ANALOG INPUT (pin 4).
2. Adjust the gain potentiometer until all output bits are 0's and the LSB flickers between 0 and 1.
3. To confirm proper operation of the device, vary the applied input voltage to obtain the output coding listed in Table 1.

Note: A single +5V supply can be used for both the +5V ANALOG and the +5V DIGITAL. If separate supplies are used, the difference between the two can not exceed 100mV. This also applies to the -5.2V supply requirements.

Datel recommends using ferrite beads to separate the analog and digital supplies (FAIR-RITE # 2643000301.)

Table 1. Output Coding

OUTPUT CODING MSB LSB	INPUT RANGE $\pm 1.25\text{V}$	BIPOLAR SCALE
00 0000 0000 0000	+1.249847	+FS -1 LSB
00 0111 1111 1111	+0.937500	+3/4 FS
00 1111 1111 1111	+0.625000	+1/2FS
01 1111 1111 1111	0.000000	0
10 1111 1111 1111	-0.625000	-1/2FS
11 0111 1111 1111	-0.937500	-3/4FS
11 1111 1111 1110	-1.249847	-FS +1 LSB
11 1111 1111 1111	-1.250000	-FS

COMP. OFF. BINARY

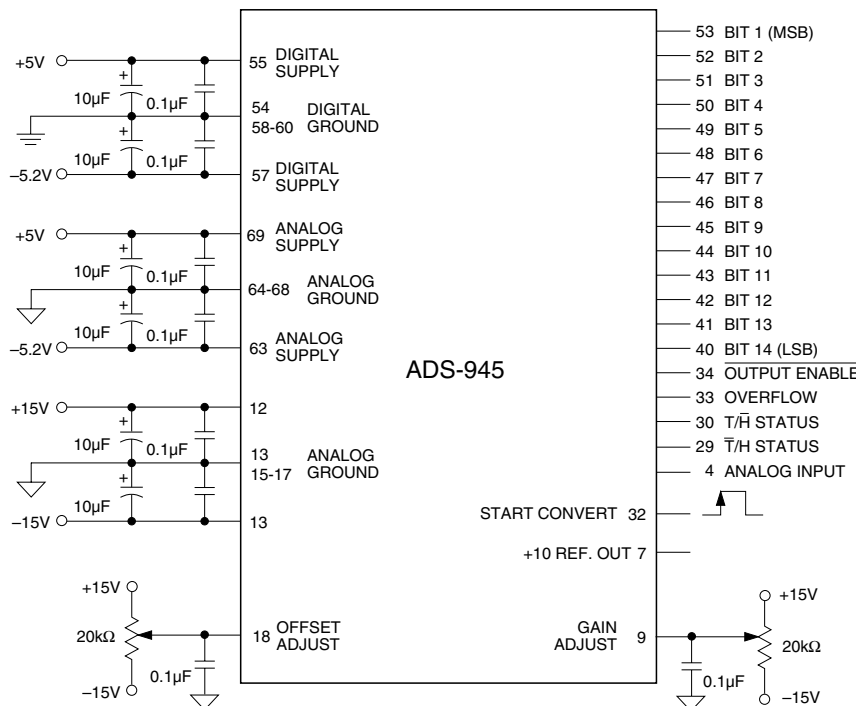

Figure 2. ADS-945 Connection Diagram

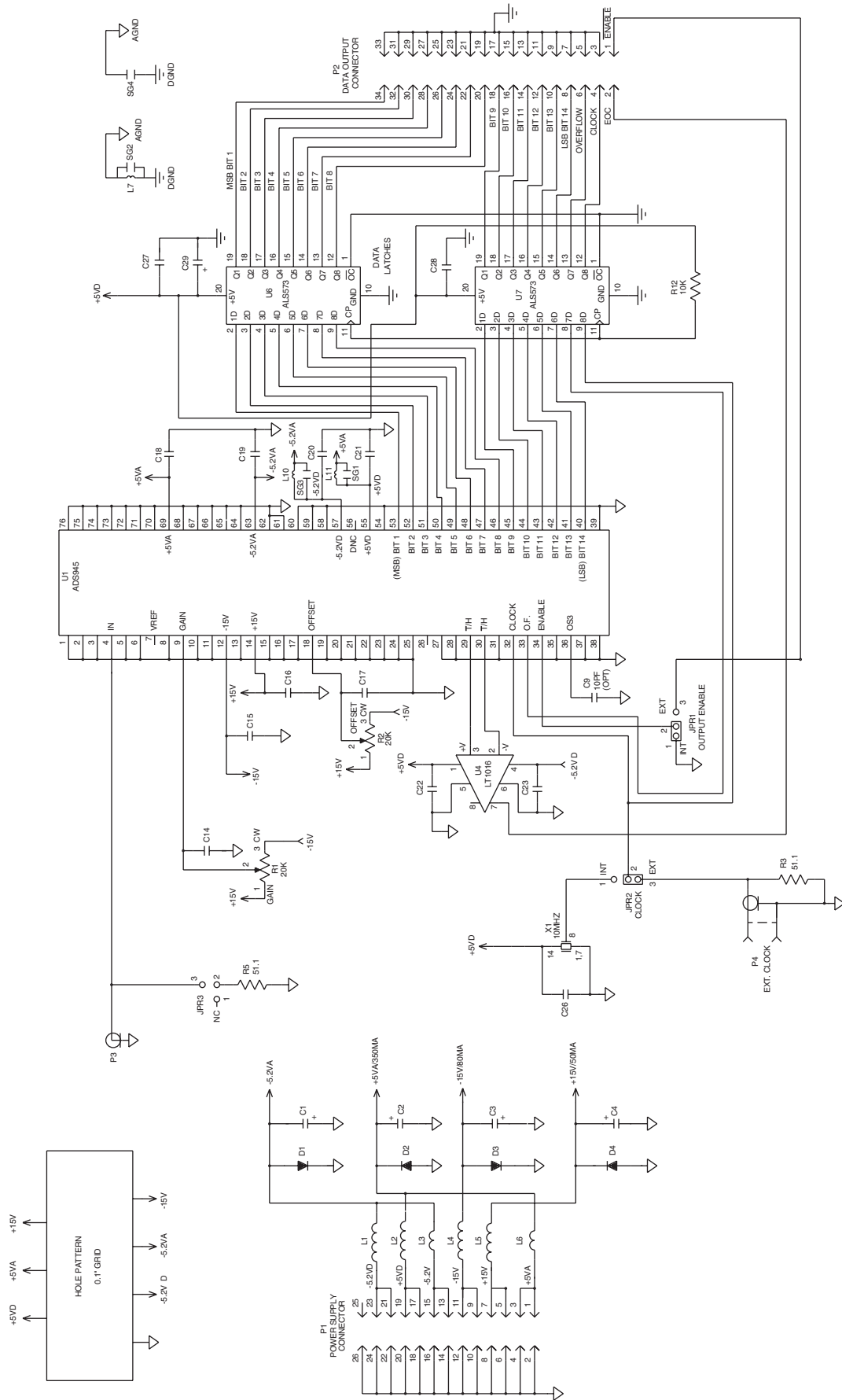

Figure 3. ADS-945 Evaluation Board Schematic (DATEL Dwg. #A-23442)

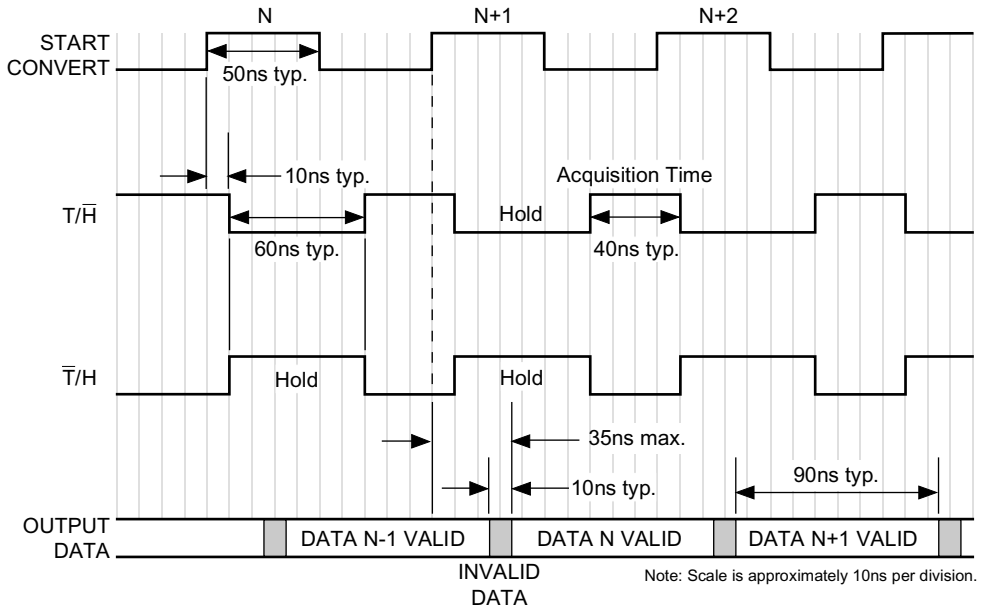

Figure 4. ADS-945 Timing Diagram

TIMING NOTES:

1. The ADS-945 is an edge-triggered device requiring no additional external timing signals. The rising edge of the start convert pulse initiates a conversion.
2. A start convert pulse of 50ns is recommended when sampling at 10MHz.
3. The falling edge of the subsequent start convert pulse (N+1) or the rising edge of the N+2 pulse can be used to latch data from conversion N (1 pipeline delay).

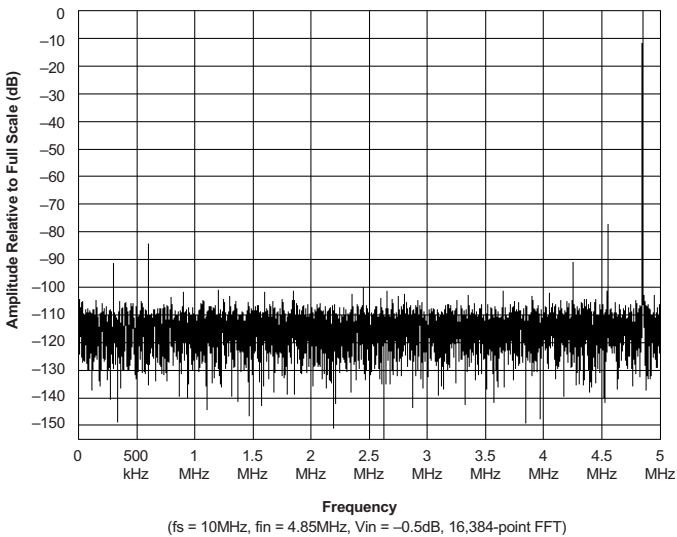
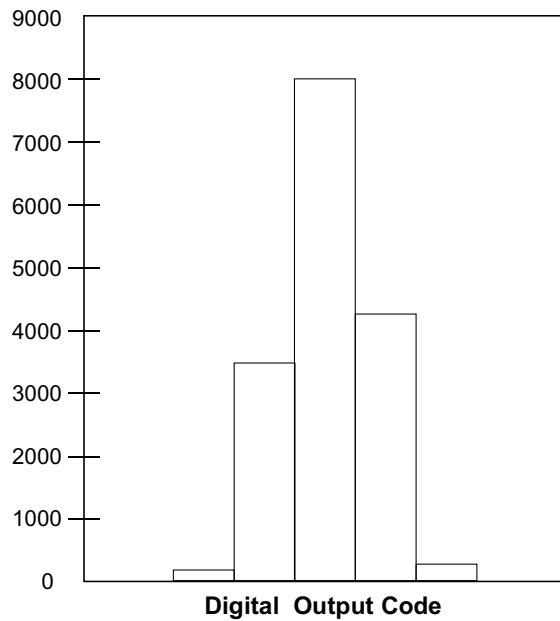

Figure 5. ADS-945 FFT Analysis



This histogram represents the typical peak-to-peak noise (including quantization noise) associated with the ADS-945. 16,384 conversions were processed with the input to the ADS-945 tied to analog ground.

Figure 6. ADS-945 Grounded Input Histogram

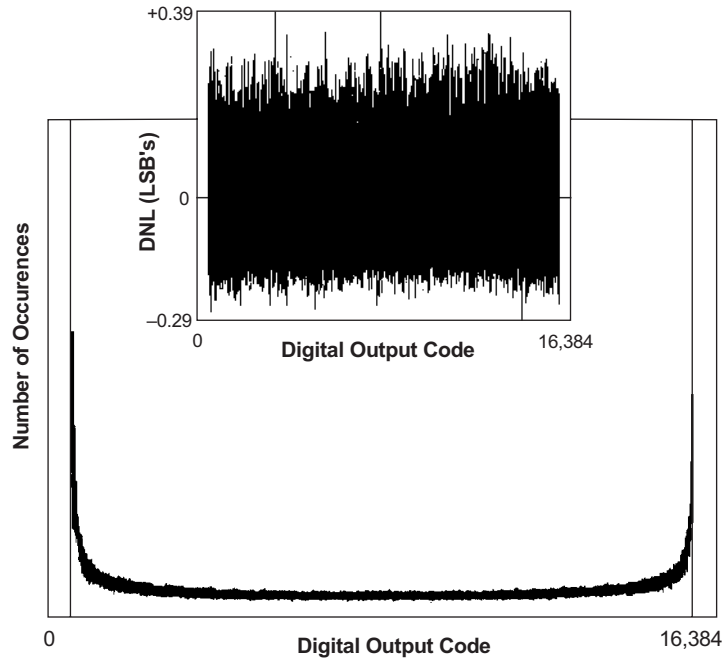

Figure 7. ADS-945 Histogram and Differential Nonlinearity

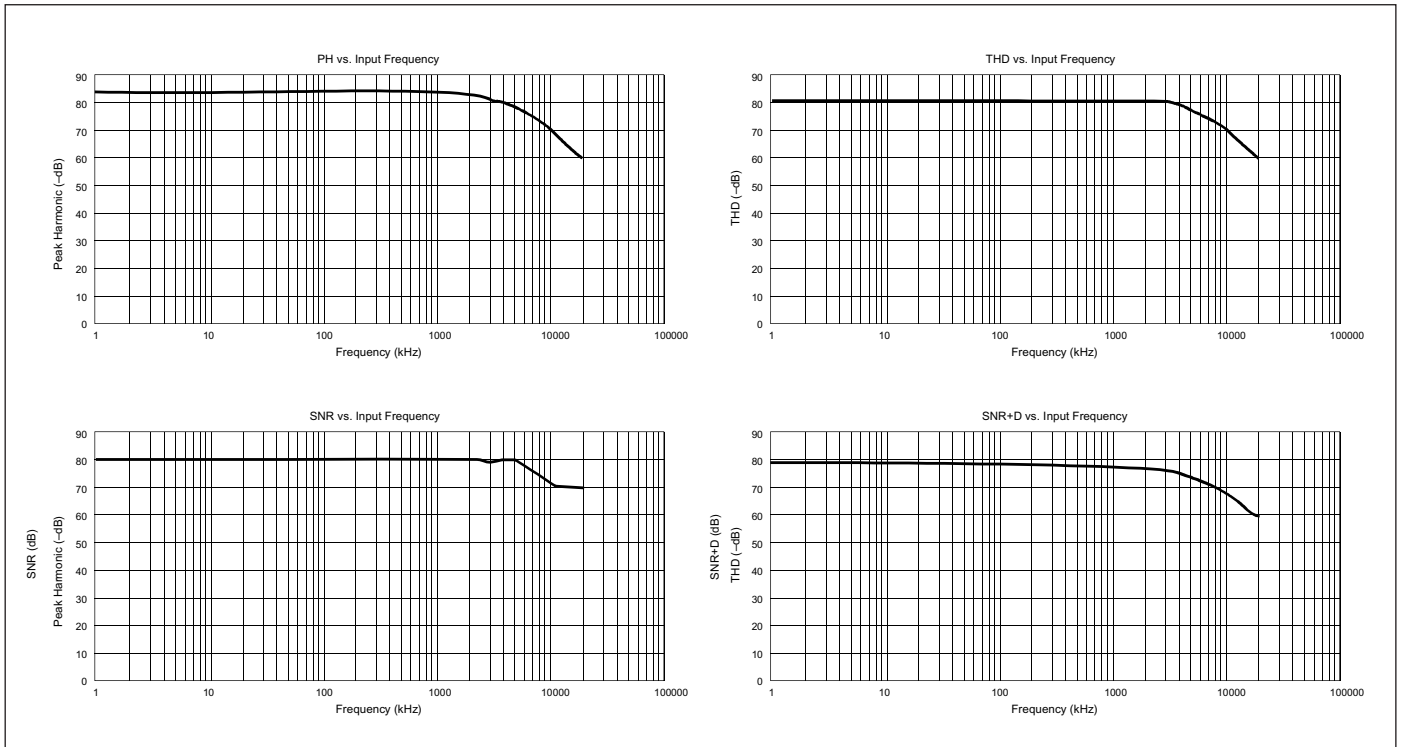
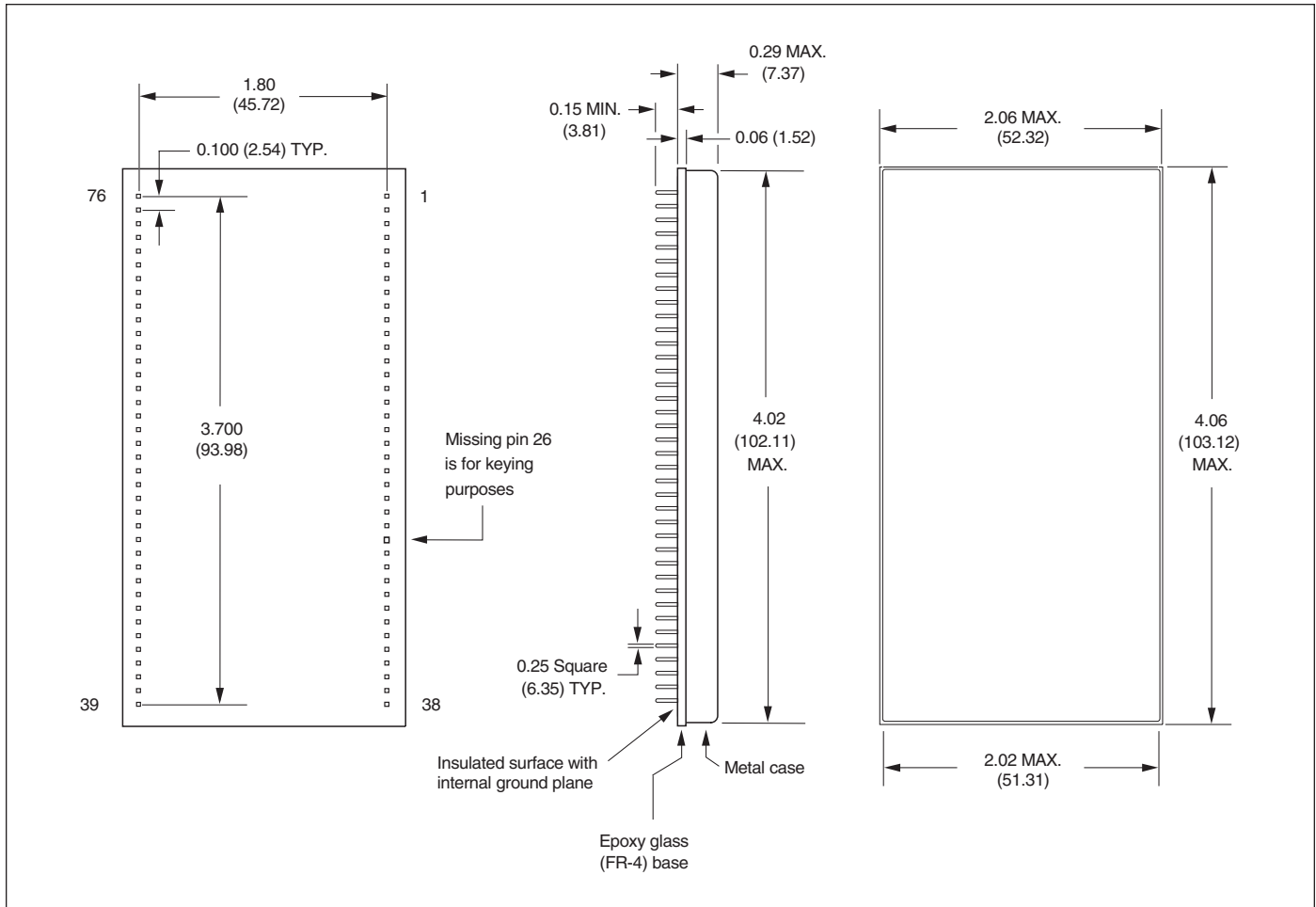

Figure 8. ADS-945 Dynamic Performance vs. Input Frequency at +25°C

MECHANICAL DIMENSIONS INCHES (mm)



ORDERING INFORMATION

MODEL NUMBER	OPERATING TEMP. RANGE	ACCESSORIES
ADS-945	0 to +70°C	ADS-945
ADS-945EX	-55 to +125°C	Evaluation Board (without ADS-945)



DATEL, Inc. 11 Cabot Boulevard, Mansfield, MA 02048-1151
 Tel: (508) 339-3000 (800) 233-2765 Fax: (508) 339-6356
 Internet: www.datel.com E-mail: sales@datel.com

ISO 9001:2000 REGISTERED

DS-0237F 5/04

DATEL (UK) LTD. Tadley, England Tel: (01256)-880444
 Internet: www.datel-europe.com E-mail: datel.ltd@datel.com

DATEL S.A.R.L. Montigny Le Bretonneux, France Tel: 01-34-60-01-01
 Internet: www.datel-europe.com E-mail: datel.sarl@datel.com

DATEL GmbH München, Germany Tel: 89-544334-0
 Internet: www.datel-europe.com E-mail: datel.gmbh@datel.com

DATEL KK Tokyo, Japan Tel: 3-3779-1031, Osaka Tel: 6-6354-2025
 Internet: www.datel-co.jp E-mail: salestko@datel.co.jp, salesosa@datel.co.jp

DATEL China Shanghai, China Tel: 011-86-51317131
 E-mail: davidx@datel.com