



FEATURES

- 16-bit resolution
- 5MHz sampling rate
- Functionally complete
- No missing codes over full HI-REL temperature range
- Edge-triggered
- $\pm 5V$, $\pm 12V$ or $\pm 15V$ supplies, 3.0 Watts
- Small, 40-pin, ceramic TDIP
- 83dB SNR, $-86dB$ THD
- Ideal for both time and frequency-domain applications

PRODUCT OVERVIEW

The ADS-935 is a 16-bit, 5MHz sampling A/D converter. This device accurately samples full-scale input signals up to Nyquist frequencies with no missing codes. The dynamic performance of the ADS-935 has been optimized to achieve a signal-to-noise ratio (SNR) of 83dB and a total harmonic distortion (THD) of $-86dB$.

Packaged in a 40-pin TDIP, the functionally complete ADS-935 contains a fast-settling sample-hold amplifier, a subranging (two-pass) A/D converter, an internal reference, timing/control logic, and error-correction circuitry. Digital input and output levels are TTL. The ADS-935 only requires the rising edge of the start convert pulse to operate.

Requiring $\pm 5V$ supplies and either $\pm 12V$ or $\pm 15V$ supplies, the ADS-935 dissipates 3.3 Watts. The device is offered with a bipolar ($\pm 2.75V$) or a unipolar (0 to $-5.5V$) analog input range. Models are available for use in either commercial (0 to $+70^\circ C$) or HI-REL (-55 to $+125^\circ C$) operating temperature ranges. A proprietary, auto-calibrating, error-correcting circuit enables the device to achieve specified performance over the full military temperature range. Typical applications include medical imaging, radar, sonar, communications and instrumentation.

INPUT/OUTPUT CONNECTIONS			
PIN	FUNCTION	PIN	FUNCTION
1	+3.2V REF. OUT	40	+12V/+15V
2	UNIPOLAR	39	-12V/-15V
3	ANALOG INPUT	38	+5V ANALOG SUPPLY
4	ANALOG GROUND	37	-5V SUPPLY
5	OFFSET ADJUST	36	ANALOG GROUND
6	GAIN ADJUST	35	COMP. BITS
7	DIGITAL GROUND	34	OUTPUT ENABLE
8	FIFO/DIR	33	OVERFLOW
9	FIFO READ	32	EOC
10	FSTAT1	31	+5V DIGITAL SUPPLY
11	FSTAT2	30	DIGITAL GROUND
12	START CONVERT	29	BIT 1 (MSB)
13	BIT 16 (LSB)	28	BIT 1 (MSB)
14	BIT 15	27	BIT 2
15	BIT 14	26	BIT 3
16	BIT 13	25	BIT 4
17	BIT 12	24	BIT 5
18	BIT 11	23	BIT 6
19	BIT 10	22	BIT 7
20	BIT 9	21	BIT 8

BLOCK DIAGRAM

POWER AND GROUNDING	
+5V ANALOG SUPPLY	38
+5V DIGITAL SUPPLY	31
-5V SUPPLY	37
ANALOG GROUND	4, 36
DIGITAL GROUND	7, 30
-12/-15V ANALOG SUPPLY	39
+12/+15V ANALOG SUPPLY	40

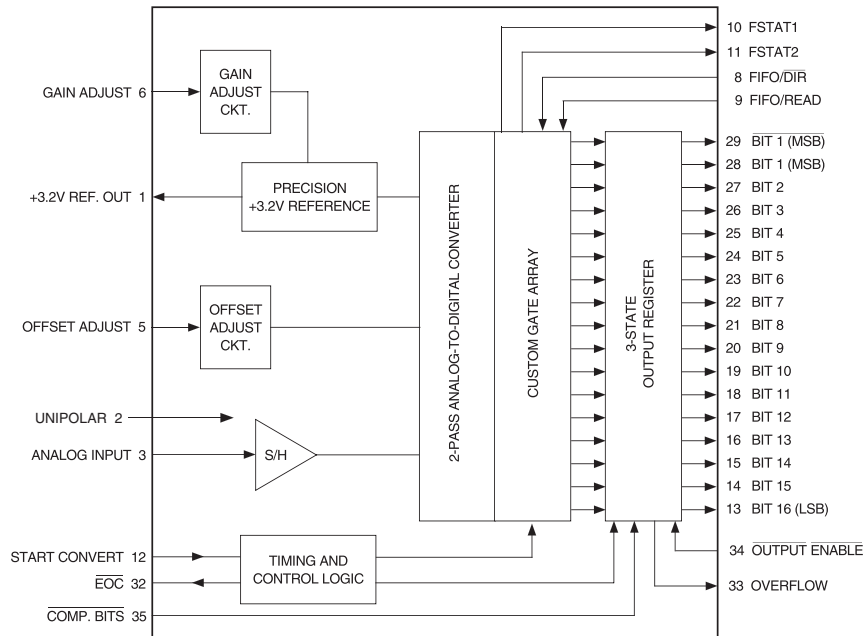

Figure 1. ADS-935 Functional Block Diagram



ABSOLUTE MAXIMUM RATINGS		
PARAMETERS	LIMITS	UNITS
+5V Supply (Pins 31, 38)	0 to +6	Volts
-5V Supply (Pin 37)	0 to -6	Volts
+12V/+15V Supply (pin 40)	0 to +16V	Volts
-12V/-15V Supply (pin 39)	0 to -16V	Volts
Digital Inputs (Pin 8, 9, 12, 34, 35)	-0.3 to +V _{DD} +0.3	Volts
Analog Input (Pin 3)	±5	Volts
Lead Temperature (10 seconds)	+300	°C

PHYSICAL/ENVIRONMENTAL				
PARAMETERS	MIN.	TYP.	MAX.	UNITS
Operating Temp. Range, Case				
ADS-935MC	0	—	+70	°C
ADS-935MM	-55	—	+125	°C
Thermal Impedance				
θ _{jc}	—	4	—	°C/Watt
θ _{ca}	—	18	—	°C/Watt
Storage Temperature Range				
	-65	—	+150	°C
Package Type				
	40-pin, metal-sealed, ceramic TDIP			
Weight				
	0.56 ounces (16 grams)			

FUNCTIONAL SPECIFICATIONS

(T_A = +25°C, ±V_{CC} = ±12/15V ±V_{DD} = ±5V, 5MHz sampling rate, and a minimum 3 minute warmup ① unless otherwise specified.)

ANALOG INPUT	+25°C			0 TO +70°C			-55 TO +125°C			UNITS
	MIN.	TYP.	MAX.	MIN.	TYP.	MAX.	MIN.	TYP.	MAX.	
DIGITAL INPUTS										
Logic Levels										
Logic "1"	+2.0	—	—	+2.0	—	—	+2.0	—	—	Volts
Logic "0"	—	—	+0.8	—	—	+0.8	—	—	+0.8	Volts
Logic Loading "1"	—	—	+20	—	—	+20	—	—	+20	µA
Logic Loading "0" ②	—	—	-20	—	—	-20	—	—	-20	µA
Start Convert Positive Pulse Width ③	20	50	—	20	50	—	20	50	—	ns
STATIC PERFORMANCE										
Resolution	—	16	—	—	16	—	—	16	—	Bits
Integral Nonlinearity (f _{in} = 10kHz)	—	±1.0	—	—	±1.5	—	—	±2.0	—	LSB
Differential Nonlinearity (f _{in} = 10kHz)	-0.95	±0.5	+1.0	-0.95	±0.5	+1.0	-0.95	±0.5	+1.5	LSB
Full Scale Absolute Accuracy	—	±0.15	±0.3	—	±0.3	±0.5	—	±0.5	±0.8	%FSR
Bipolar Zero Error (Tech Note 2)	—	±0.1	±0.2	—	±0.2	±0.4	—	±0.4	±0.6	%FSR
Bipolar Offset Error (Tech Note 2)	—	±0.1	±0.2	—	±0.2	±0.4	—	±0.4	±0.6	%FSR
Gain Error (Tech Note 2)	—	±0.15	±0.3	—	±0.3	±0.5	—	±0.5	±0.8	%FSR
No Missing Codes (f _{in} = 10kHz)	16	—	—	16	—	—	16	—	—	Bits
DYNAMIC PERFORMANCE										
Peak Harmonics (-0.5dB)										
dc to 500kHz	—	-87	-82	—	-87	-82	—	-82	-78	dB
500kHz to 2.45MHz	—	-82	-80	—	-82	-80	—	-78	-78	dB
Total Harmonic Distortion (-0.5dB)										
dc to 500kHz	—	-86	-81	—	-86	-81	—	-81	-76	dB
500kHz to 1MHz	—	-81	-80	—	-81	-80	—	-77	-76	dB
Signal-to-Noise Ratio (w/o distortion, -0.5dB)										
dc to 500kHz	84	86	—	84	86	—	77	80	—	dB
500kHz to 2.45MHz	82	85	—	82	85	—	77	80	—	dB
Signal-to-Noise Ratio ④ (& distortion, -0.5dB)										
dc to 500kHz	80	82	—	80	82	—	76	78	—	dB
500kHz to 2.45MHz	79	81	—	79	81	—	76	75	—	dB
Two-tone Intermodulation										
Distortion (f _{in} = 200kHz, f _s = 5MHz, -0.5dB)										
Noise	—	-86	-85	—	-86	-85	—	-86	-82	dB
	—	80	—	—	80	—	—	80	—	µVrms
Input Bandwidth (-3dB)										
Small Signal (-20dB input)										
	—	25	—	—	25	—	—	25	—	MHz
Large Signal (-0.5dB input)										
	—	15	—	—	25	—	—	15	—	MHz
Feedthrough Rejection (f _{in} = 1MHz)										
	—	90	—	—	90	—	—	90	—	dB
Slew Rate										
	—	±400	—	—	±400	—	—	±400	—	V/µs
Aperture Delay Time										
	—	4	—	—	4	—	—	4	—	ns
Aperture Uncertainty										
	—	2	—	—	2	—	—	2	—	ps rms
S/H Acquisition Time (to ±0.001%FSR, 5.5V step)										
	—	80	—	—	80	—	—	90	—	ns
Overvoltage Recovery Time ⑤										
	—	200	—	—	200	—	—	200	—	ns
A/D Conversion Rate										
	5	—	—	5	—	—	5	—	—	MHz

ANALOG OUTPUT	+25°C			0 to +70°C			-55 to +125°C			UNITS
	MIN.	TYP.	MAX.	MIN.	TYP.	MAX.	MIN.	TYP.	MAX.	
Internal Reference										
Voltage	—	+3.2	—	—	+3.2	—	—	+3.2	—	Volts
Drift	—	±30	—	—	±30	—	—	±30	—	ppm/°C
External Current	—	5	—	—	5	—	—	5	—	mA
DIGITAL OUTPUTS										
Logic Levels										
Logic "1"	+2.4	—	—	+2.4	—	—	+2.4	—	—	Volts
Logic "0"	—	—	+0.4	—	—	+0.4	—	—	+0.4	Volts
Logic Loading "1"	—	—	-4	—	—	-4	—	—	-4	mA
Logic Loading "0"	—	—	+4	—	—	+4	—	—	+4	mA
Output Coding ⑥	(Offset) Binary / Complementary (Offset) Binary / Two's Complement / Complementary Two's Complement									
POWER REQUIREMENTS										
Power Supply Ranges ⑦										
+5V Supply	+4.75	+5.0	+5.25	+4.75	+5.0	+5.25	+4.9	+5.0	+5.25	Volts
-5V Supply	-4.75	-5.0	-5.25	-4.75	-5.0	-5.25	-4.9	-5.0	-5.25	Volts
+12V Supply ⑧	+11.5	+12.0	+12.5	+11.5	+12.0	+12.5	+11.5	+12.0	+12.5	Volts
-12V Supply ⑧	-11.5	-12.0	-12.5	-11.5	-12.0	-12.5	-11.5	-12.0	-12.5	Volts
+15V Supply ⑧	+14.5	+15.0	+15.5	+14.5	+15.0	+15.5	+14.5	+15.0	+15.5	Volts
-15V Supply ⑧	-14.5	-15.0	-15.5	-14.5	-15.0	-15.5	-14.5	-15.0	-15.5	Volts
Power Supply Currents										
+5V Supply	—	+240	—	—	+240	—	—	+240	—	mA
-5V Supply	—	-150	—	—	-150	—	—	-150	—	mA
-12/15V Supply ⑧	—	-50	—	—	-50	—	—	-50	—	mA
+12/15V Supply ⑧	—	+65	—	—	+65	—	—	+65	—	mA
Power Dissipation	—	3.3	—	—	3.3	—	—	3.3	—	Watts
Power Supply Rejection	—	—	±0.07	—	—	±0.07	—	—	±0.07	%FSR/%V

Footnotes:

- ① All power supplies must be on before applying a start convert pulse. All supplies and the clock (START CONVERT) must be present during warmup periods. The device must be continuously converting during this time.
- ② When COMP. BITS (pin 35) is low, logic loading "0" will be -350µA.
- ③ A 5MHz clock with a 50nsec positive pulse width is used for all production testing. See Timing Diagram for more details.
- ④ Effective bits is equal to:

$$\frac{(\text{SNR} + \text{Distortion}) - 1.76}{6.02} + \left[20 \log \frac{\text{Full Scale Amplitude}}{\text{Actual Input Amplitude}} \right]$$
- ⑤ This is the time required before the A/D output data is valid once the analog input is back within the specified range.
- ⑥ The minimum supply voltages of +4.9V and -4.9V for ±V_{DD} are required for -55°C operation only. The minimum limits are +4.75V and -4.75V when operating at +125°C.
- ⑦ The minimum supply voltages of +4.9V and -4.9V for ±V_{DD} are required for -55°C operation only. The minimum limits are +4.75V and -4.75V when operating at +125°C.
- ⑧ ±12V only or ±15V only required.

TECHNICAL NOTES

- Obtaining fully specified performance from the ADS-935 requires careful attention to pc-card layout and power supply decoupling. The device's analog and digital ground systems are connected to each other internally. For optimal performance, tie all ground pins ((4, 7, 30 and 36) directly to a large analog ground plane beneath the package.

For the best performance it is recommended to use a single power source for both the +5V analog and +5V digital supplies. Bypass all power supplies and the +3.2V reference output to ground with 4.7µF tantalum capacitors in parallel with 0.1µF ceramic capacitors. Locate the bypass capacitors as close to the unit as possible.
- The ADS-935 achieves its specified accuracies without the need for external calibration. If required, the device's small initial offset and gain errors can be reduced to zero using the adjustment circuitry shown in Figure 2. When using this circuitry, or any similar offset and gain calibration hardware, make adjustments following warmup. To avoid interaction, always adjust offset before gain. Tie pins 5 and 6 to ANALOG GROUND (pin 4) if not using offset and gain adjust circuits.
- Pin 35 (COMP. BITS) is used to select the digital output coding format of the ADS-935 (see Tables 2a and 2b). When this pin has a TTL logic "0" applied, it complements all of the ADS-935's digital outputs.

When pin 35 has a logic "1" applied, the output coding is complementary offset binary. Applying a logic "0" to pin 35 changes the coding to offset

binary. Using the MSB output (pin 29) instead of the MSB output (pin 28) changes the respective output codings to complementary two's complement and two's complement.

Pin 35 is TTL compatible and can be directly driven with digital logic in applications requiring dynamic control over its function. There is an internal pull-up resistor on pin 35 allowing it to be either connected to +5V or left open when a logic "1" is required.

- To enable the three-state outputs, connect OUTPUT ENABLE (pin 34) to a logic "0" (low). To disable, connect pin 34 to a logic "1" (high).
- Applying a start convert pulse while a conversion is in progress (\overline{EOC} = logic "1") will initiate a new and probably inaccurate conversion cycle. Data from both the interrupted and subsequent conversions will be invalid.
- Do not enable/disable or complement the output bits or read from the FIFO during the conversion process (from the rising edge of \overline{EOC} to the falling edge of \overline{EOC}).
- The OVERFLOW bit (pin 33) switches from 0 to 1 when the input voltage exceeds that which produces an output of all 1's or when the input equals or exceeds the voltage that produces all 0's. When COMP BITS is activated, the above conditions are reversed.

INTERNAL FIFO OPERATION

The ADS-935 contains an internal, user-initiated, 18-bit, 16-word FIFO memory. Each word in the FIFO contains the 16 data bits as well as the $\overline{\text{MSB}}$ and OVERFLOW bits. Pins 8 (FIFO/DIR) and 9 (FIFO READ) control the FIFO's operation. The FIFO's status can be monitored by reading pins 10 (FSTAT1) and 11 (FSTAT2).

When pin 8 (FIFO/DIR) has a logic "1" applied, the FIFO is inserted into the digital data path. When pin 8 has a logic "0" applied, the FIFO is transparent and the output data goes directly to the output three-state register (whose operation is controlled by pin 34 (ENABLE)). Read and write commands to the FIFO are ignored when the ADS-935 is operated in the "direct" mode. It takes a maximum of 20ns to switch the FIFO in or out of the ADS-935's digital data path.

FIFO WRITE and READ Modes

Once the FIFO has been enabled (pin 8 high), digital data is automatically written to it, regardless of the status of FIFO READ (pin 9). Assuming the FIFO is initially empty, it will accept data (18-bit words) from the next 16 consecutive A/D conversions. As a precaution, pin 9 (which controls the FIFO's READ function) should not be low when data is first written to an empty FIFO.

When the FIFO is initially empty, digital data from the first conversion (the "oldest" data) appears at the output of the FIFO immediately after the first conversion has been completed and remains there until the FIFO is read.

If the output three-state register has been enabled (logic "0" applied to pin 34), data from the first conversion will appear at the output of the ADS-935. Attempting to write a 17th word to a full FIFO will result in that data, and any subsequent conversion data, being lost.

Once the FIFO is full (indicated by FSTAT1 and FSTAT2 both equal to "1"), it can be read by dropping the FIFO READ line (pin 9) to a logic "0" and then applying a series of 15 rising edges to the read line. Since the first data word is already present at the FIFO output, the first read command (the first rising edge applied to FIFO READ) will bring data from the second conversion to the output. Each subsequent read command/rising edge brings the next word to the output lines. After the 15th rising edge brings the 16th data word to the FIFO output, the subsequent falling edge on READ will update the status outputs (after a 20ns maximum delay) to FSTAT1 = 0, FSTAT2 = 1 indicating that the FIFO is empty.

If a read command is issued after the FIFO empties, the last word (the 16th conversion) will remain present at the outputs.

FIFO Reset Feature

At any time, the FIFO can be reset to an empty state by putting the ADS-935 into its "direct" mode (logic "0" applied to pin 8, FIFO/DIR) and also applying a logic "0" to the FIFO READ line (pin 9). The empty status of the FIFO will be indicated by FSTAT1 going to a "0" and FSTAT2 going to a "1". The status outputs change 40ns after applying the control signals.

FIFO Status, FSTAT1 and FSTAT2

Monitor the status of the data in the FIFO by reading the two status pins, FSTAT1 (pin 10) and FSTAT2 (pin 11).

CONTENTS	FSTAT1	FSTAT2
Empty (0 words)	0	1
<half full (≤ 8 words)	0	0
half-full or more (≥ 8 words)	1	0
Full (16 words)	1	1

DELAY	PIN	TRANSITION	MIN.	TYP.	MAX.	UNITS
Direct mode to FIFO enabled	8		–	10	20	ns
FIFO enabled to direct mode	8		–	10	20	ns
FIFO READ to output data valid	9		–	–	40	ns
FIFO READ to status update when changing from <half full (1 word) to empty	9		–	–	20	ns
FIFO READ to status update when changing from \geq half full (8 words) to <half full (7 words)	9		–	–	110	ns
FIFO READ to status update when changing from full (16 words) to \geq half full (15 words)	9		–	–	190	ns
Falling edge of $\overline{\text{EOC}}$ to status update when writing first word into empty FIFO	32		–	–	190	ns
Falling edge of $\overline{\text{EOC}}$ to status update when changing FIFO from <half full (7 words) to \geq half full (8 words)	32		–	–	110	ns
Falling edge of $\overline{\text{EOC}}$ to status update when filling FIFO with 16th word	32		–	–	28	ns

Table 1. FIFO Delays

CALIBRATION PROCEDURE

Connect the converter per Figure 2. Any offset/gain calibration procedures should not be implemented until the device is fully warmed up. To avoid interaction, adjust offset before gain. The ranges of adjustment for the circuits in Figure 2 are guaranteed to compensate for the ADS-935's initial accuracy errors and may not be able to compensate for additional system errors.

A/D converters are calibrated by positioning their digital outputs exactly on the transition point between two adjacent digital output codes. This is accomplished by connecting LED's to the digital outputs and performing adjustments until certain LED's "flicker" equally between on and off. Other approaches employ digital comparators or microcontrollers to detect when the outputs change from one code to the next.

For the ADS-935, offset adjusting is normally accomplished when the analog input is 0 minus 1/2 LSB (-42µV). See Table 2b for the proper bipolar output coding.

Gain adjusting is accomplished when the analog input is at nominal full scale minus 1/2 LSB's (+2.749874V).

Note: Connect pin 5 to ANALOG GROUND (pin 4) for operation without zero/offset adjustment. Connect pin 6 to pin 4 for operation without gain adjustment.

OUTPUT FORMAT	PIN 35 LOGIC LEVEL
Complementary (Offset) Binary	1
(Offset) Binary	0
Complementary Two's Complement (Using MSB, pin 29)	1
Two's Complement (Using MSB, pin 29)	0

Table 2a. Setting Output Coding Selection (Pin 35)

Zero/Offset Adjust Procedure

1. Apply a train of pulses to the START CONVERT input (pin 12) so that the converter is continuously converting.
2. For zero/offset adjust, apply -42µV to the ANALOG INPUT (pin 3).
3. Adjust the offset potentiometer until the code flickers between 1000 0000 0000 0000 and 0111 1111 1111 1111 with pin 35 tied high (complementary offset binary) or between 0111 1111 1111 1111 and 1000 0000 0000 0000 with pin 35 tied low (offset binary).
4. Two's complement coding requires using BIT 1 (MSB) (pin 29). With pin 35 tied low, adjust the trimpot until the output code flickers between all 0's and all 1's.

Gain Adjust Procedure

1. For gain adjust, apply +2.749874V to the ANALOG INPUT (pin 3).
2. Adjust the gain potentiometer until all output bits are 0's and the LSB flickers between a 1 and 0 with pin 35 tied high (complementary offset binary) or until all output bits are 1's and the LSB flickers between a 1 and 0 with pin 35 tied low (offset binary).
3. Two's complement coding requires using BIT 1 (MSB) (pin 29). With pin 35 tied low, adjust the gain trimpot until the output code flickers equally between 0111 1111 1111 1111 and 0111 1111 1111 1110.
4. To confirm proper operation of the device, vary the applied input voltage to obtain the output coding listed in Table 2b.

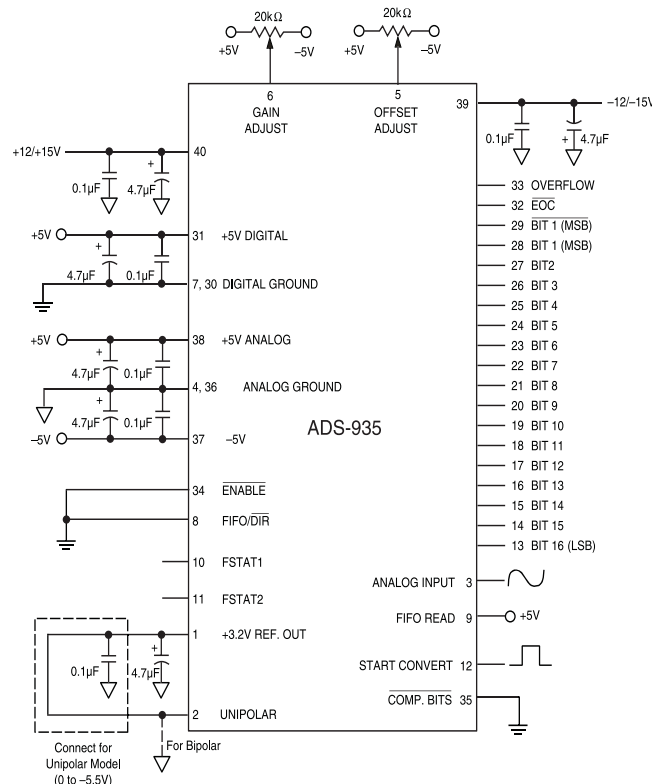

Figure 2. Bipolar Connection Diagram

UNIPOLAR SCALE	INPUT RANGE	COMP. BINARY		BINARY		COMP. TWO'S COMP.		TWO'S COMP.		INPUT RANGE	BIPOLAR SCALE
		MSB	LSB	MSB	LSB	MSB	LSB	MSB	LSB		
0 -1 LSB	-0.000084	1111	1111 1111 1111	0000	0000 0000 0000	0111	1111 1111 1111	1000	0000 0000 0000	+2.749916	+FS -1 LSB
0 -1/2 LSB	-0.000126	LSB "1" to "0"		LSB "0" to "1"		LSB "1" to "0"		LSB "0" to "1"		+2.749874	+FS -1/2 LSB
0 -1/8 FS	-0.687500	1110	0000 0000 0000	0001	1111 1111 1111	0110	0000 0000 0000	1001	1111 1111 1111	+2.062500	+3/4 FS
0 -1/4 FS	-1.375000	1100	0000 0000 0000	0011	1111 1111 1111	0100	0000 0000 0000	1011	1111 1111 1111	+1.375000	+1/2 FS
-1/2 FS - 1/2LSB	-2.749958	1000	0000 0000 0000	0111	1111 1111 1111	0000	0000 0000 0000	1111	1111 1111 1111	0.000000	0
-1/2 LSB	-2.750000	0111	1111 1111 1111	1000	0000 0000 0000	1111	1111 1111 1111	0000	0000 0000 0000	-0.000084	-1/2 LSB
-3/4 FS	-4.125000	0100	0000 0000 0000	1011	1111 1111 1111	1100	0000 0000 0000	0011	1111 1111 1111	-1.375000	-1/2 FS
-7/8 FS	-4.812500	0010	0000 0000 0000	1101	1111 1111 1111	1010	0000 0000 0000	0101	1111 1111 1111	-2.062500	-3/4 FS
-FS +1 LSB	-5.499916	0000	0000 0000 0001	1111	1111 1111 1110	1000	0000 0000 0001	0111	1111 1111 1110	-2.749916	-FS +1 LSB
-FS + 1/2 LSB	-5.499958	LSB "0" to "1"		LSB "1" to "0"		LSB "0" to "1"		LSB "1" to "0"		-2.749958	-FS + 1/2 LSB
-FS	-5.500000	0000	0000 0000 0000	1111	1111 1111 1111	1000	0000 0000 0000	0111	1111 1111 1111	-2.750000	-FS
		OFFSET BINARY		COMP. OFF. BIN.		TWO'S COMP.		COMP. TWO'S COMP.			

Table 2b. Output Coding

THERMAL REQUIREMENTS

All DATEL sampling A/D converters are fully characterized and specified over operating temperature (case) ranges of 0 to +70°C and -55 to +125°C. All room-temperature (T_A = +25°C) production testing is performed without the use of heat sinks or forced-air cooling. Thermal impedance figures for each device are listed in their respective specification tables.

These devices do not normally require heat sinks, however, standard precautionary design and layout procedures should be used to ensure devices do

not overheat. The ground and power planes beneath the package, as well as all pcb signal runs to and from the device, should be as heavy as possible to help conduct heat away from the package. Electrically insulating, thermally-conductive "pads" may be installed underneath the package. Devices should be soldered to boards rather than "socketed", and of course, minimal air flow over the surface can greatly help reduce the package temperature.

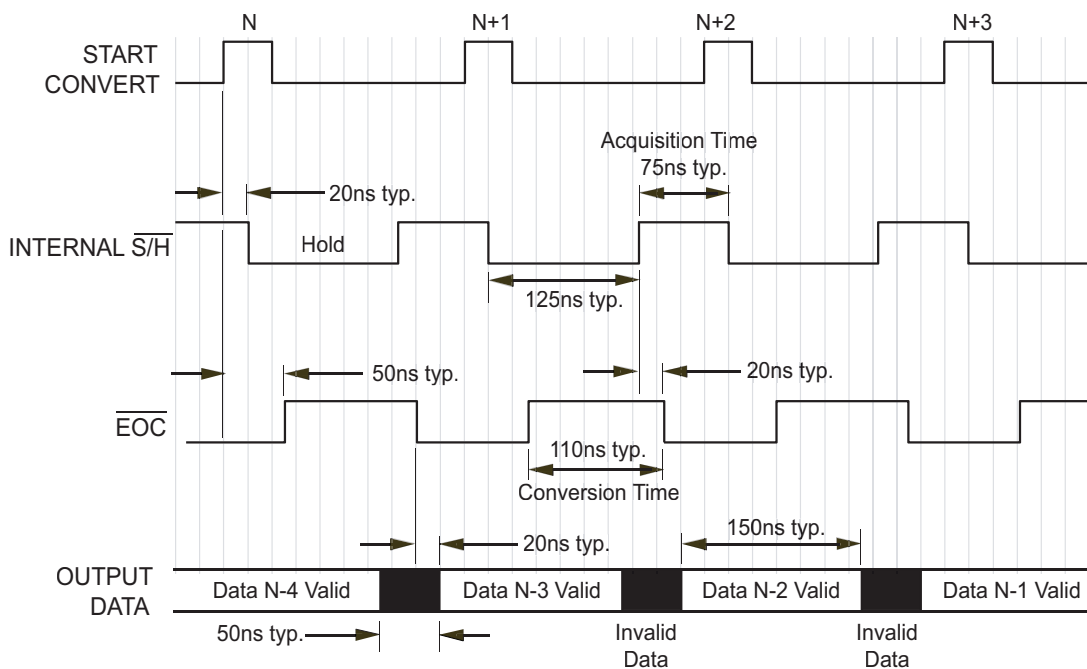

NOTES:

1. Scale is approximately 20ns per division. fs = 5MHz
2. This device has three pipeline delays. Four start convert pulses (clock cycles) must be applied for valid data from the first conversion to appear at the output of the A/D.

Figure 3. ADS-935 Timing Diagram

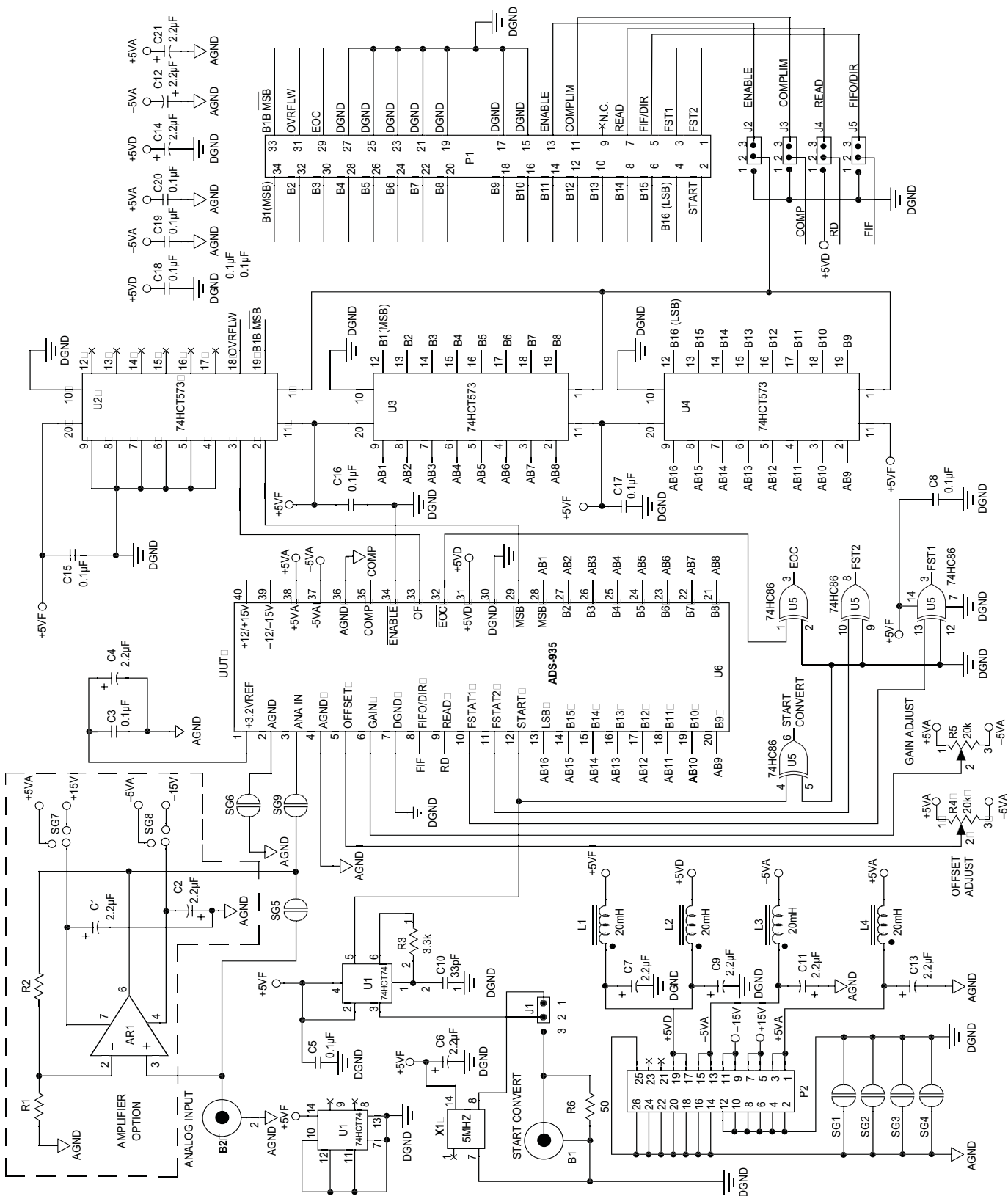
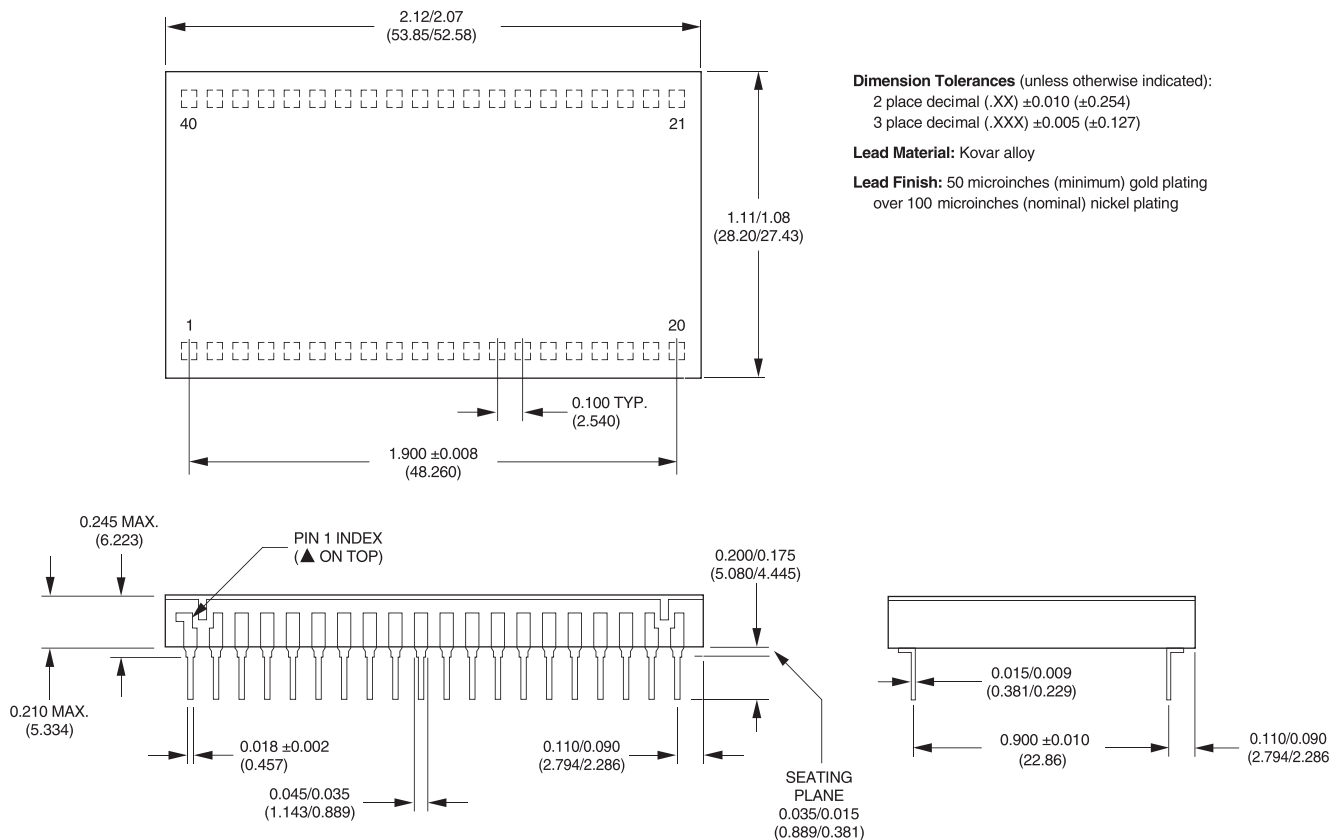

Figure 4. ADS-935 Evaluation Board Schematic

Preliminary Evaluation Board - Modified ADS-B933 to include ±12V or ±15V Supplies to U6

MECHANICAL DIMENSIONS - INCHES (mm)



ORDERING INFORMATION			
MODEL NUMBER	OPERATING TEMP. RANGE	ACCESSORIES	
ADS-935MC	0 to +70°C	ADS-B935	Evaluation Board (without ADS-935)
ADS-935MM	-55 to +125°C	HS-40	Heat Sink for all ADS-935 models

Receptacles for PC board mounting can be ordered through AMP, Inc., Part # 3-331272-8 (Component Lead Socket), 40 required. For MIL-STD-883 product, or surface mount packaging, contact DATEL.